

Performanse računarskih sistema
Rešenja zadataka

1. Videti predavanja.

2.

Kretanje	Verovatnoća	Opis
1→1	$p_{11} = \frac{1}{4} \cdot \frac{1}{4} = \frac{1}{16}$	Kretanje u istom segmentu veličine 100
1→2	$p_{12} = \frac{1}{4} \cdot \frac{3}{4} = \frac{3}{16}$	Kretanje iz segmenta veličine 100 u segment veličine 300
2→1	$p_{21} = \frac{3}{4} \cdot \frac{1}{4} = \frac{3}{16}$	Kretanje iz segmenta veličine 300 u segment veličine 100
2→2	$p_{22} = \frac{3}{4} \cdot \frac{3}{4} = \frac{9}{16}$	Kretanje u istom segmentu veličine 300

$$\begin{aligned} t_{11} &= \frac{2}{100^2} \int_0^{100} (100-x) \cdot 0.5 \cdot x \cdot dx = \frac{1}{100^2} \int_0^{100} (100 \cdot x - x^2) \cdot dx = \\ &= \frac{1}{100^2} \left(100 \cdot \frac{1}{2} x^2 \Big|_0^{100} - \frac{1}{3} x^3 \Big|_0^{100} \right) = 50 - \frac{100}{3} = 16.66ms \\ t_{11} &= \frac{2}{300^2} \int_0^{300} (300-x) \cdot 0.5 \cdot x \cdot dx = \frac{1}{300^2} \int_0^{300} (300 \cdot x - x^2) \cdot dx = \\ &= \frac{1}{300^2} \left(300 \cdot \frac{1}{2} x^2 \Big|_0^{300} - \frac{1}{3} x^3 \Big|_0^{300} \right) = 150 - \frac{300}{3} = 50ms = 3t_{11} \end{aligned}$$

$$t_{12} = t_{21} = \frac{1}{300} \int_{z=500}^{800} \left(\frac{1}{100} \int_{200}^{300} f(z-x) \cdot dx \right) \cdot dz = \frac{1}{30000} \int_{z=300}^{600} \left(\int_0^{100} f(z-x) \cdot dx \right) \cdot dz = \frac{1}{30000} I [ms]$$

$$I = \int_{z=300}^{400} \left(\int_0^{100} 0.5 \cdot (z-x) \cdot dx \right) \cdot dz + \int_{z=500}^{600} \left(\int_0^{100} 10\sqrt{z-x} \cdot dx \right) \cdot dz + \int_{z=400}^{500} \left(\int_{z-400}^{100} 0.5 \cdot (z-x) \cdot dx + \int_0^{z-400} 10\sqrt{z-x} \cdot dx \right) \cdot dz =$$

$$= I_1 + I_2 + I_3$$

$$I_1 = \int_{z=300}^{400} \left(\int_0^{100} 0.5 \cdot (z-x) \cdot dx \right) \cdot dz = \int_{z=300}^{400} (50 \cdot z - 2500) \cdot dz = 25 \cdot z^2 \Big|_{z=300}^{400} - 250000 = 250000 \cdot 6 = 15 \cdot 10^5$$

$$I_2 = \int_{z=500}^{600} \left(\int_0^{100} 10\sqrt{z-x} \cdot dx \right) \cdot dz = -\frac{20}{3} \int_{z=500}^{600} (z-x)^{3/2} \Big|_{x=0}^{100} \cdot dz = \frac{20}{3} \int_{z=500}^{600} (z^{3/2} - (z-100)^{3/2}) \cdot dz =$$

$$= \frac{8}{3} (z^{5/2} - (z-100)^{5/2}) \Big|_{z=500}^{600} = \frac{800000}{3} (z^{5/2} - (z-1)^{5/2}) \Big|_{z=5}^6 = \frac{800000}{3} (6^{5/2} - 2 \cdot 5^{5/2} + 4^{5/2}) = 22.342 \cdot 10^5$$

$$I_3 = \int_{z=400}^{500} \left(\int_{z-400}^{100} 0.5 \cdot (z-x) \cdot dx + \int_0^{z-400} 10\sqrt{z-x} \cdot dx \right) \cdot dz = \int_{z=400}^{500} \left(-\frac{1}{4} \cdot (z-x)^2 \Big|_{z-400}^{100} - \frac{20}{3} (z-x)^{3/2} \Big|_{x=0}^{z-400} \right) \cdot dz =$$

$$= \frac{1}{4} \int_{z=400}^{500} (400^2 - (z-100)^2) \cdot dz + \frac{20}{3} \int_{z=400}^{500} (z^{3/2} - 400^{3/2}) \cdot dz = 25 \cdot 400^2 - \frac{1}{12} z^3 \Big|_{300}^{400} + \frac{8}{3} z^{5/2} \Big|_{400}^{500} - \frac{2000}{3} 400^{3/2} =$$

$$= 10^6 \left[4 - \frac{37}{12} + \frac{8}{30} (5^{5/2} - 4^{5/2}) - \frac{16}{3} \right] = 19.571 \cdot 10^5$$

$$I = I_1 + I_2 + I_3 = 56.913 \cdot 10^5$$

$$t_{12} = t_{21} = \frac{1}{30000} I [ms] = 189.71ms$$

$$\bar{T}_{am} = p_{11} \cdot t_{11} + p_{12} \cdot t_{12} + p_{21} \cdot t_{21} + p_{22} \cdot t_{22} = 100.308ms$$

$$\bar{T}_{rd} = \frac{1}{2} T_{rev} = \frac{30}{N_{rev}} = 4.166ms$$

$$T_{dt} = \frac{1}{12} T_{rev} = \frac{5}{N_{rev}} = 0.6944ms$$

$$\bar{T}_{uk} = 1200 \cdot (\bar{T}_{am} + \bar{T}_{rd} + T_{dt}) = 1200 \cdot 105.168ms = 126.202s = 2min6.202s$$

3. Šematski prikaz sistema dat je na sledećoj slici:

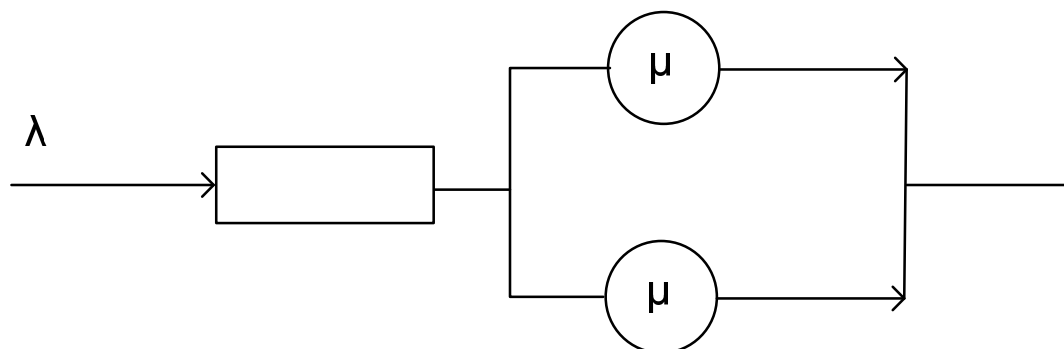

Ako intenzitet pristizanja zahteva u sistem obeležimo sa λ , $\lambda = \frac{1}{a}$, $\bar{a} = 10ms$, a intenzitet obrade jednog kanala sa μ , $\mu = \frac{1}{s}$, $\bar{s} = 5ms$, tada dijagram stanja sistema izgleda kao na narednoj slici:

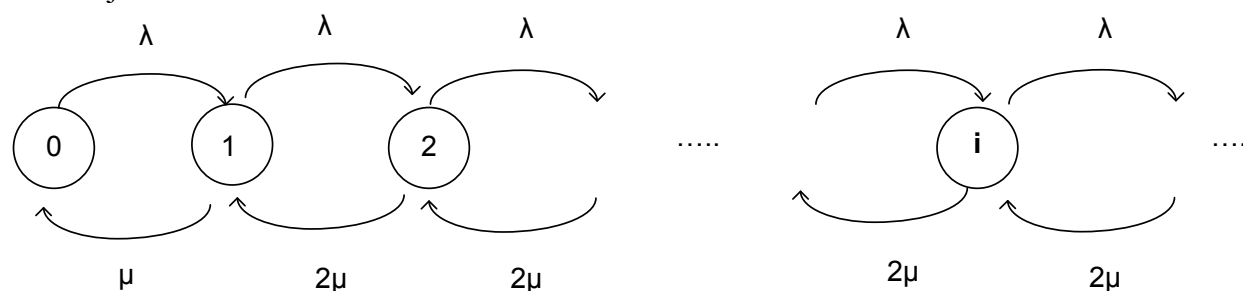

Stanje i predstavlja ono stanje sistema u kome u serveru postoji i zahteva.

Neka je $\frac{\lambda}{\mu} = \rho$. Balansne jednačine za ovaj sistem:

$$p_0 \cdot \lambda = p_1 \cdot \mu \Rightarrow p_1 = \frac{\lambda}{\mu} \cdot p_0 = \rho \cdot p_0$$

$$p_1 \cdot \lambda = p_2 \cdot 2\mu \Rightarrow p_2 = \frac{\lambda}{2\mu} \cdot p_1 = \frac{\rho^2}{2} \cdot p_0$$

$$p_2 \cdot \lambda = p_3 \cdot 2\mu \Rightarrow p_3 = \frac{\lambda}{2\mu} \cdot p_2 = \frac{\rho^3}{2^2} \cdot p_0$$

...

$$p_{n-1} \cdot \lambda = p_n \cdot 2\mu \Rightarrow p_n = \frac{\lambda}{2\mu} \cdot p_{n-1} = \frac{\rho^n}{2^{n-1}} \cdot p_0$$

$$\sum_i p_i = 1 \Rightarrow p_0 \cdot \left(1 + \rho + \frac{\rho^2}{2} + \dots + \frac{\rho^n}{2^{n-1}} + \dots \right) = 1$$

$$p_0 \cdot \left(1 + \rho \left(1 + \frac{\rho}{2} + \left(\frac{\rho}{2} \right)^2 + \dots + \left(\frac{\rho}{2} \right)^n + \dots \right) \right) = p_0 \cdot \left(1 + \frac{\rho}{1 - \frac{\rho}{2}} \right) = p_0 \cdot \frac{2 + \rho}{2 - \rho} = 1$$

$$\rho = \frac{\lambda}{\mu} = \frac{\bar{s}}{a} = 0.5$$

$$p_0 = \frac{2 - \rho}{2 + \rho} = 0.6$$

$$p_1 = \rho \cdot p_0 = 0.3$$

$$\text{Iskorišćenje servera: } U = 1 - \left(p_0 + \frac{1}{2} p_1 \right) = 0.25$$

Srednji broj poslova u sistemu:

$$\begin{aligned} J &= \sum_{i=0}^{\infty} i \cdot p_i = \sum_{i=1}^{\infty} i \cdot p_i = p_1 + \sum_{i=2}^{\infty} i \cdot p_i = p_1 + p_0 \cdot \sum_{i=2}^{\infty} i \cdot \rho^{i-1} = p_0 \cdot \left(\rho + \sum_{i=2}^{\infty} i \cdot \frac{\rho^i}{2^{i-1}} \right) = \\ &= p_0 \cdot \rho \cdot \sum_{i=1}^{\infty} i \cdot \frac{\rho^{i-1}}{2^{i-1}} = p_0 \cdot \rho \cdot \frac{1}{\left(1 - \frac{\rho}{2} \right)^2} = \frac{4 \cdot p_0 \cdot \rho}{(2 - \rho)^2} = 0.53333 \end{aligned}$$

$$\text{Produktivnost: } X = \sum_{i=0}^{\infty} \lambda \cdot p_i = \lambda \cdot \sum_{i=0}^{\infty} p_i = \lambda = \frac{1}{a} = 100 \text{ posl / sec}$$

$$\text{Vreme odziva: } \bar{T} = \frac{J}{X} = \frac{J}{\lambda} = J \cdot a = 5.333 \text{ ms}$$

$$\text{Srednje vreme čekanja: } \bar{T}_q = \bar{T} - \bar{s} = 0.333 \text{ ms}$$

4.

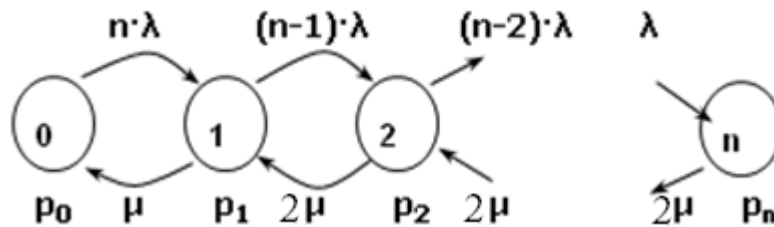

Ako sa λ označimo intenzitet generisanja zahteva od strane jednog terminala ,

$\lambda = \frac{1}{\bar{\theta}}$, gde je $\bar{\theta}$ srednje vreme razmišljanja korisnika (terminala) ,

a sa μ označimo srednju brzinu procesora, odnosno intenzitet opsluživanja korisničkih zahteva,

($\mu = \frac{1}{\bar{s}}$, gde je \bar{s} srednje vreme servisiranja zahteva), tada su balansne jednačine za ovaj sistem:

$$p_0 \cdot n \cdot \lambda = p_1 \cdot \mu \Rightarrow p_1 = p_0 \cdot n \cdot 2\rho, \text{ gde je sa } \rho \text{ obeležen odnos } \frac{\lambda}{2\mu} = \frac{1}{6}$$

$$p_1 \cdot (n-1) \cdot \lambda = p_2 \cdot 2\mu \Rightarrow p_2 = p_0 \cdot n \cdot (n-1) \cdot 2\rho^2$$

....

$$p_{n-1} \cdot \lambda = p_n \cdot 2\mu \Rightarrow p_n = p_0 \cdot n \cdot (n-1) \cdot \dots \cdot 1 \cdot 2\rho^n = p_0 \cdot n! \cdot 2\rho^n$$

Zbir svih verovatnoća je 1, pa dobijamo:

$$p_0(1 + 2n\rho + 2n(n-1)\rho^2 + \dots + 2n!\rho^n) = 1$$

$$\frac{1}{p_0(n)} = 1 + 2n\rho + 2n(n-1)\rho^2 + \dots + 2n!\rho^n$$

Možemo uočiti da važi sledeća rekurzivna veza:

$$\frac{1}{p_0(n-1)} = 1 + 2(n-1)\rho + 2(n-1)(n-2)\rho^2 + \dots + 2(n-1)!\rho^{n-1}$$

$$\frac{1}{p_0(n)} = 1 + n\rho + n\rho \cdot \frac{1}{p_0(n-1)}$$

$$\frac{1}{p_0(n)} = 1 + \frac{n}{6} \cdot \left(1 + \frac{1}{p_0(n-1)} \right)$$

$$p_0(n) = \frac{1}{1 + \frac{n}{6} \cdot \left(1 + \frac{1}{p_0(n-1)} \right)}$$

a)

$$U = 1 - p_0 - \frac{1}{2}p_1 = \frac{16}{43} \Rightarrow p_0 + \frac{1}{2}p_1 = \frac{27}{43}$$

$$p_0(1) = \frac{3}{4}, p_1(1) = \frac{1}{3}p_0(1) = \frac{1}{4}, p_0(1) + \frac{1}{2}p_1(1) = \frac{7}{8} \neq \frac{27}{43}$$

$$p_0(2) = \frac{9}{16}, p_1(2) = \frac{2}{3}p_0(2) = \frac{3}{8}, p_0(1) + \frac{1}{2}p_1(1) = \frac{12}{16} \neq \frac{27}{43}$$

$$p_0(3) = \frac{18}{43}, p_1(3) = \frac{3}{3}p_0(3) = \frac{18}{43}, p_0(3) + \frac{1}{2}p_1(3) = \frac{27}{43} \Rightarrow \boxed{n=3}$$

b) Za onaj deo jednog interakcijskog ciklusa kada procesori radi sa terminalima, potrebno je da se obradi svih n terminala na dva procesora.

$$(\bar{\theta} + \bar{r}) \cdot U = \frac{n \cdot s}{2}$$

Stoga je

$$\bar{r} = \frac{n \cdot s}{2U} - \bar{\theta} = 10.3125ms$$

c) Kritičan broj terminala u ovom sistemu dobija se iz jednačine:

$$\bar{\theta} = (n^* - 1) \cdot \frac{s}{2}$$

$$n^* = \frac{2 \cdot \bar{\theta}}{s} + 1 = 7$$

Dodavanjem još dva terminala neće se dostići kritičan broj terminala.

Ako se vreme niskoprioritetne obrada u prisustvu 3 terminala obeležimo sa T_3 , a za slučaj sa 3 terminala obeležimo sa T_5 , tada je

$$T_3 \cdot (p_0(3) + \frac{1}{2} p_1(3)) = T_5 \cdot (p_0(5) + \frac{1}{2} p_1(5))$$

$$\frac{1}{p_0(4)} = 1 + \frac{4}{6} \cdot \left(1 + \frac{1}{p_0(3)}\right) = \frac{88}{27}$$

$$p_0(5) = \frac{1}{1 + \frac{5}{6} \cdot \left(1 + \frac{1}{p_0(4)}\right)} = \frac{162}{737}$$

$$p_1(5) = \frac{5}{3} p_0(5) = \frac{270}{737}$$

$$T_5 = \frac{T_3 \cdot (1 - U_3)}{p_0(5) + \frac{1}{2} p_1(5)} = \frac{30s \cdot \frac{27}{43}}{\frac{297}{737}} = 46.744s$$

5.

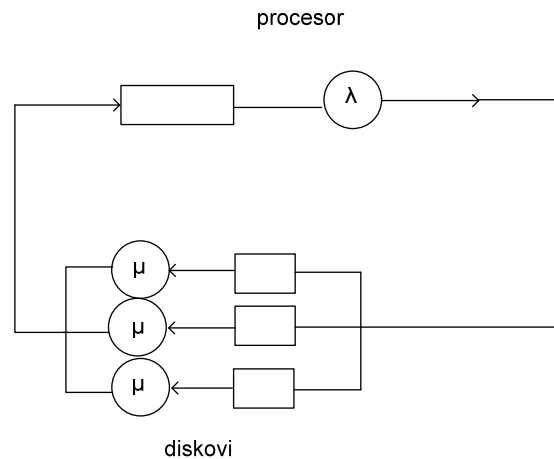

a)

Gordon-Newell-ove jednačine za data 4 resursa:

$$-(1 - p_{11})\mu_1 x_1 + p_{21}\mu_2 x_2 + p_{31}\mu_3 x_3 + p_{41}\mu_4 x_4 = 0$$

$$p_{12}\mu_1 x_1 - (1 - p_{22})\mu_2 x_2 + p_{32}\mu_3 x_3 + p_{42}\mu_4 x_4 = 0$$

$$p_{13}\mu_1 x_1 + p_{23}\mu_2 x_2 - (1 - p_{33})\mu_3 x_3 + p_{43}\mu_4 x_4 = 0$$

$$p_{14}\mu_1 x_1 + p_{24}\mu_2 x_2 + p_{34}\mu_3 x_3 - (1 - p_{44})\mu_4 x_4 = 0$$

$$\mu_1 = \lambda = \frac{1}{5ms}, \mu_2 = \mu_3 = \mu_4 = \mu = \frac{1}{15ms}$$

$$p_{12} = p_{13} = 0.3, p_{14} = 0.4,$$

$p_{21} = p_{31} = p_{41} = 1$, ostale verovatnoće su jednake nuli.

$$-\lambda x_1 + \mu x_2 + \mu x_3 + \mu x_4 = 0$$

$$0.3\lambda x_1 - \mu = 0$$

$$0.3\lambda x_1 - \mu x_3 = 0$$

$$0.4\lambda x_1 - \mu x_4 = 0$$

Neka je $x_1 = 1$

$$x_2 = 0.3 \cdot \frac{\lambda}{\mu} = 0.3 \cdot \frac{s_d}{s_p} = 0.9 = x_3$$

$$x_4 = 0.4 \cdot \frac{\lambda}{\mu} = 1.2$$

```
public class Jun08 {
    private static final int k=4;
    private static final double x[]={1,0.9,0.9,1.2};
    private static final double s[]={0.005,0.015,0.015,0.015};
    public static double buzen(int n){
        double G[]=new double[n+1];
        G[0]=1;
        for(int i=1; i<=n; i++) G[i]=0;
        for(int j=0; j<k; j++){
            for(int i=1; i<=n; i++)
                G[i]+=x[j]*G[i-1];
        }
        return G[n-1]/G[n];
    }
    public static void main(String[] args){
        int n=Integer.parseInt(args[0]);
        double g=buzen(n);
        double u1=x[0]*g, u2=x[1]*g, u3=x[2]*g, u4=x[3]*g;
        System.out.println("Iskoriscenje procesora: " +u1 );
        System.out.println("Iskoriscenje diska 1: " + u2);
        System.out.println("Iskoriscenje diska 2: " + u3);
        System.out.println("Iskoriscenje diska 3: " + u4);

        System.out.println("Protok kroz procesor: " +u1/s[0]);
        System.out.println("Protok kroz disk 1: "+u2/s[1]);
        System.out.println("Protok kroz disk 2: "+u3/s[2]);
        System.out.println("Protok kroz disk 3: "+u4/s[3]);
    }
}
```

Rezultat:

Iskoriscenje procesora: 0.4969775047071648
Iskoriscenje diska 1: 0.44727975423644833
Iskoriscenje diska 2: 0.44727975423644833
Iskoriscenje diska 3: 0.5963730056485977
Protok kroz procesor: 99.39550094143296
Protok kroz disk 1: 29.81865028242989
Protok kroz disk 2: 29.81865028242989
Protok kroz disk 3: 39.758200376573186

b)

$$V_1 = 1,$$

$$V_2 = V_3 = 0.3 \cdot V_1 = 0.3$$

$$V_4 = 0.4 \cdot V_1 = 0.4$$

$$D_1 = s_p \cdot V_1 = 5ms$$

$$D_2 = D_3 = s_d \cdot V_2 = 4.5ms$$

$$D_4 = s_d \cdot V_4 = 6ms$$

n	1	2	3
R1[ms]	5.0	6.25	7.492522
R2[ms]	4.5	5.5125	6.478564
R3[ms]	4.5	5.5125	6.478564
R4[ms]	6.0	7.8	9.732801
R [ms]	20.0	25.075	30.18245
X1[posl/ms]	0.05	0.079760	0.099395
X2[posl/ms]	0.015	0.023928	0.029818
X3[posl/ms]	0.015	0.023928	0.029818
X4[posl/ms]	0.020	0.031904	0.039758
X [posl/ms]	0.05	0.079760	0.099395
U1	0.25	0.398803	0.496977
U2	0.225	0.358923	0.447279
U3	0.225	0.358923	0.447279
U4	0.3	0.478564	0.596373
Q1	0.25	0.498504	0.744723
Q2	0.225	0.439680	0.643940
Q3	0.225	0.439680	0.643940
Q4	0.3	0.622133	0.967396

Iskoriscenje procesora: 0.496977
Iskoriscenje diska 1: 0.447279
Iskoriscenje diska 2: 0.447279
Iskoriscenje diska 3: 0.5963730056485977
Protok kroz procesor: 99.395 posl/sec
Protok kroz disk 1: 29.818 posl/sec
Protok kroz disk 2: 29.818 posl/sec
Protok kroz disk 3: 39.758 posl/sec