

# ALTERA CYCLONE III EP3C16 Development & Education BOARD

SCHEMATIC	CONTENT	PAGE
TOP	COVER PAGE, TOP	01 ~ 03
MEMORY	SDRAM,FLASH	04 ~ 05
DISPLAY	VGA, LED, 7SEGMENT	06 ~ 07
IN/OUT	CLOCK, PS2, RS232, BUTTON, SWITCH, CONNECTOR,SD CARD	08 ~ 12
FPGA	Cyclone II EP3C16 BANK1..BANK8 , POWER , CONFIG	13 ~ 17
POWER	POWER 1.2V,2.5V, 3.3V, 5V	18 ~ 18
USB BLASTER	USB BLASTER	19 ~ 19

 <small>Copyright © 2010 by Terasic Technology Inc. Taiwan. All rights reserved. No part of this schematic design may be reproduced, duplicated, or transmitted in any form without permission of Terasic.</small>		
<b>ALTERA DE0</b>		
Size B	Document Number COVER PAGE	Rev 0A
Date: Monday, September 27, 2010 Sheet 1 of 19		

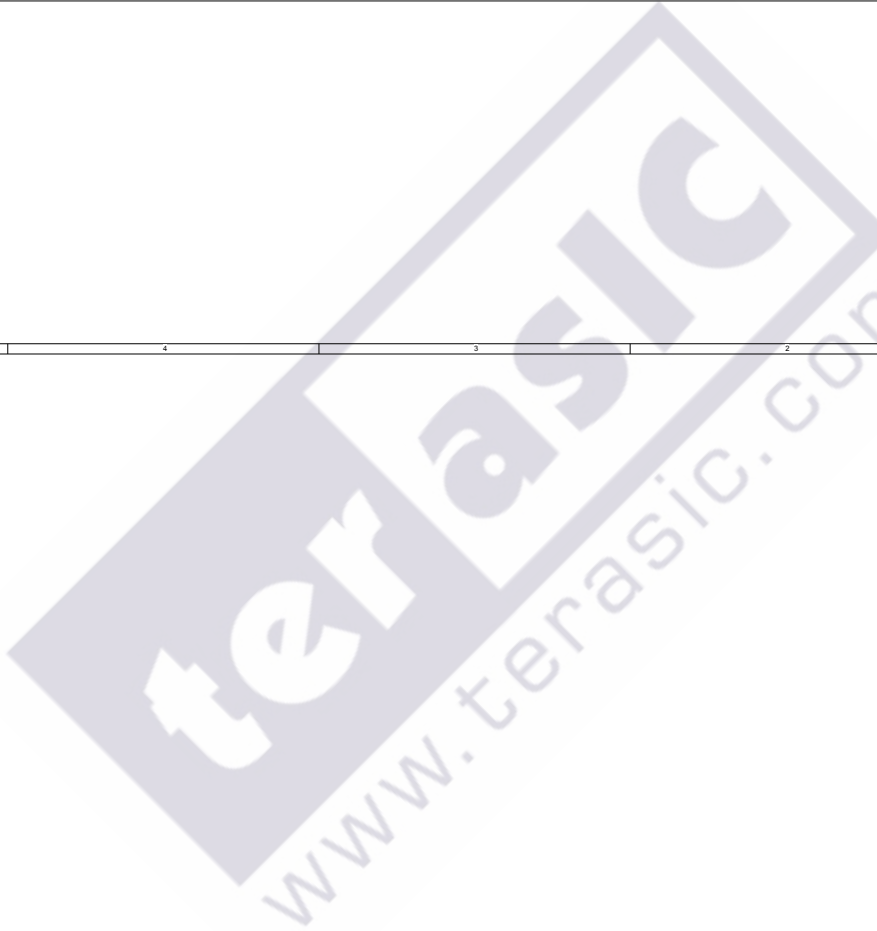

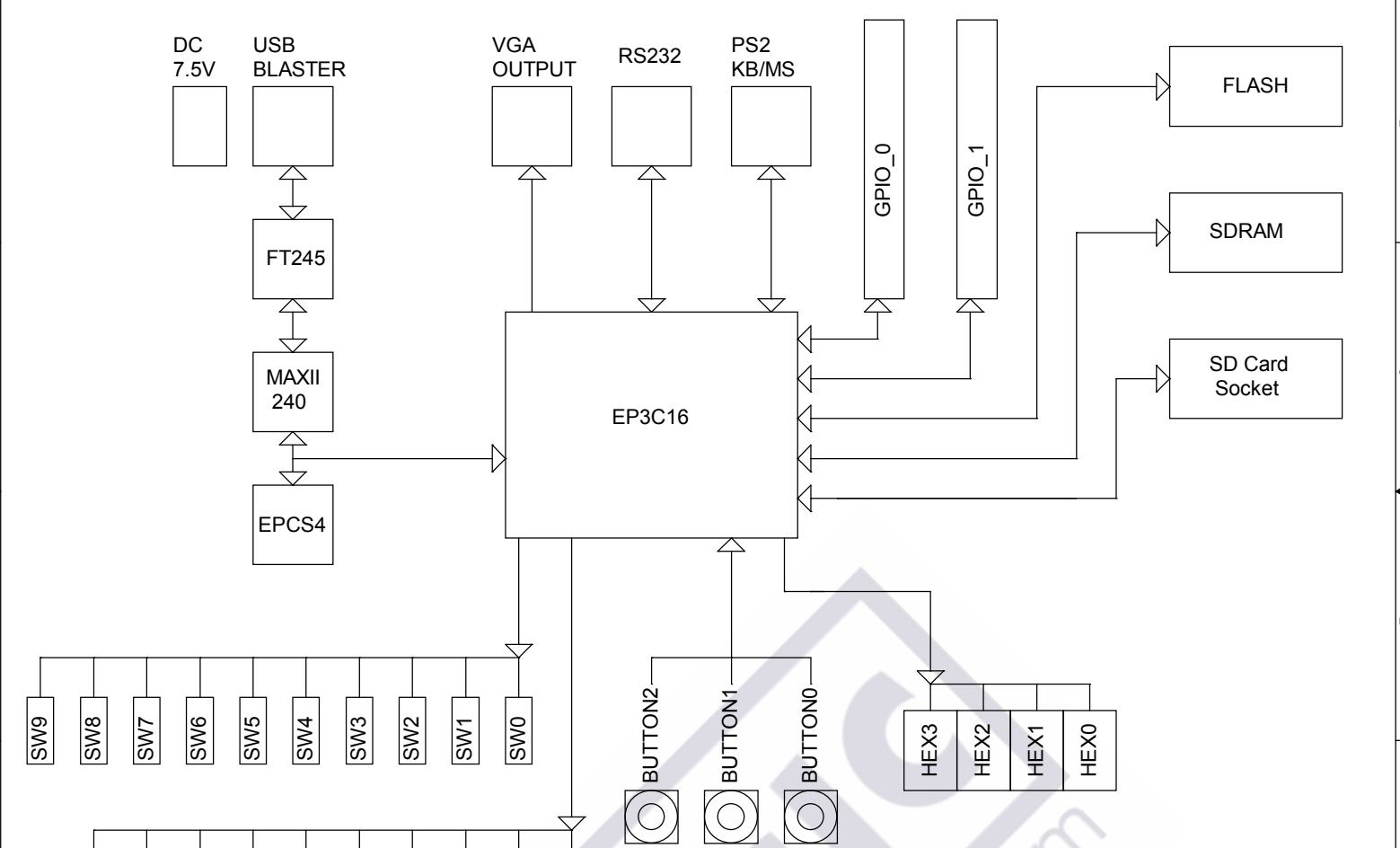

Copyright © 2007 by Terasic Technology Inc. Taiwan. All rights reserved. No part of this schematic design may be reproduced, duplicated, or used without the prior written permission of Terasic.			
<b>Title</b>			
<b>ALTERA DE0</b>			
<b>Size</b>	<b>Document Number</b>		<b>Rev</b>
Custom	PLACEMENT		0A
<b>Date:</b>	Monday, September 27, 2010	<b>Sheet</b>	2 of 19

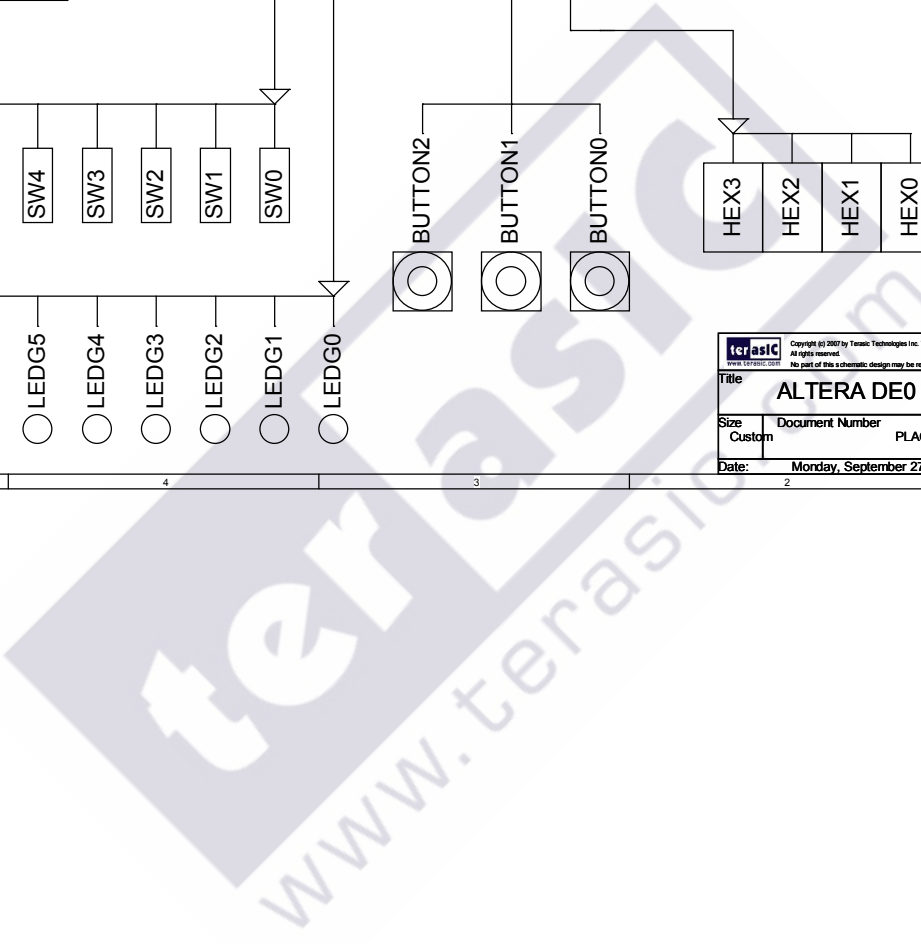

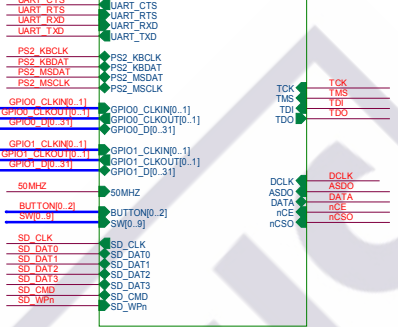
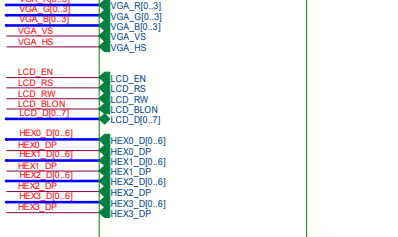
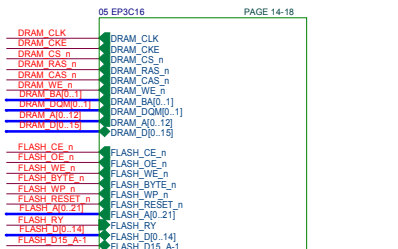
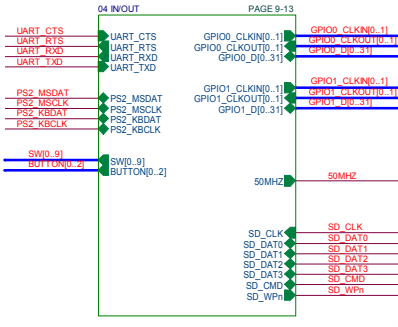
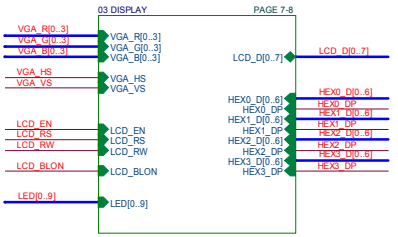
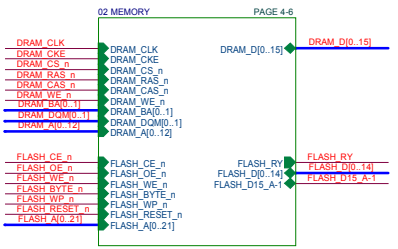

		Copyright © 2010 Altera Corporation. All rights reserved. No part of this document may be reproduced, stored in a retrieval system, or transmitted in any form or by any means, electronic, mechanical, photocopying, recording, or by any information storage and retrieval system, without the prior written permission of Altera Corporation.
File:	ALTERA DE0	
Size:	Document Number:	Rev:
B	TOP LEVEL	0A
Date:	Monday, September 27, 2010	Sheet 3 of 19



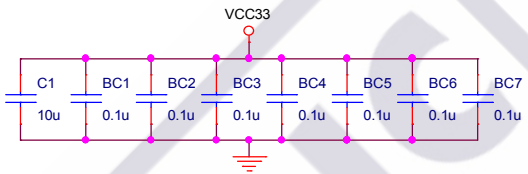
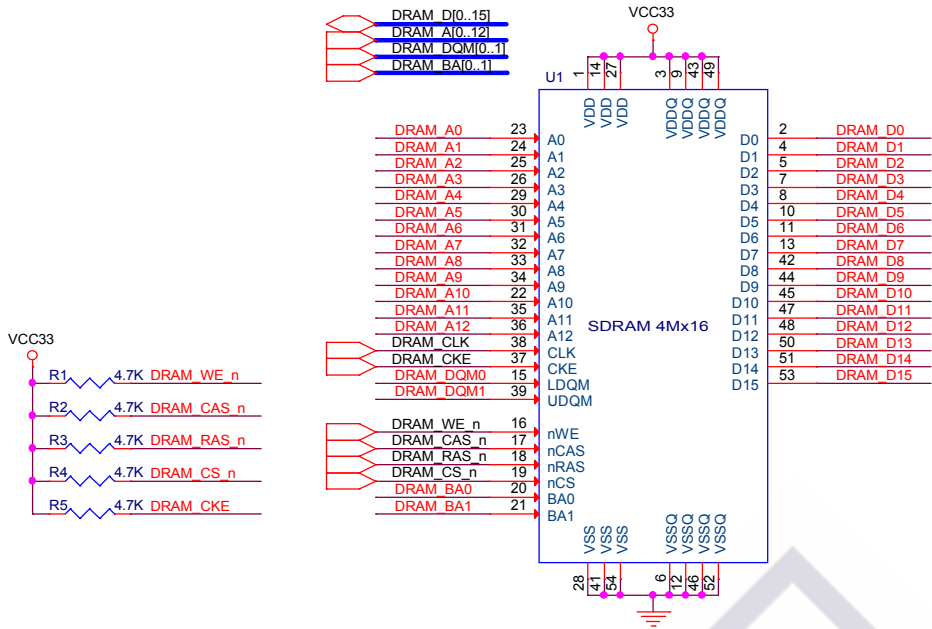

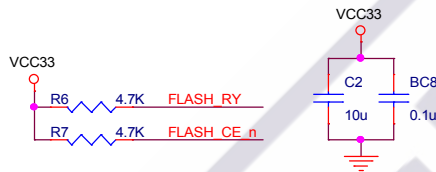
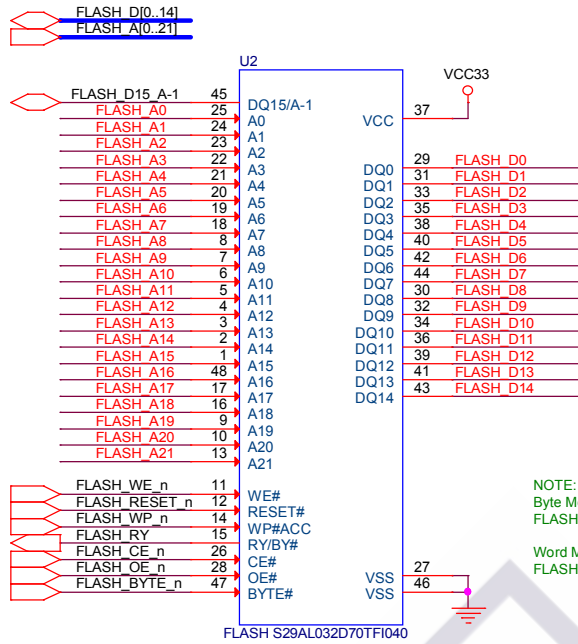

NOTE:  
 SDRAM 4Mx16 (Default)  
 SDRAM 8Mx16  
 SDRAM 16Mx16  
 SDRAM 32Mx16

Copyright (c) 2007 by Terasic Technologies Inc. Taiwan. All rights reserved. No part of this schematic design may be reproduced, duplicated, or used without the prior written permission of Terasic.	
<b>Title</b> ALTERA DE0	
<b>Size</b> A	<b>Document Number</b> SDRAM
<b>Date:</b> Monday, September 27, 2010	<b>Rev</b> 0A
5	4
3	2
1	1

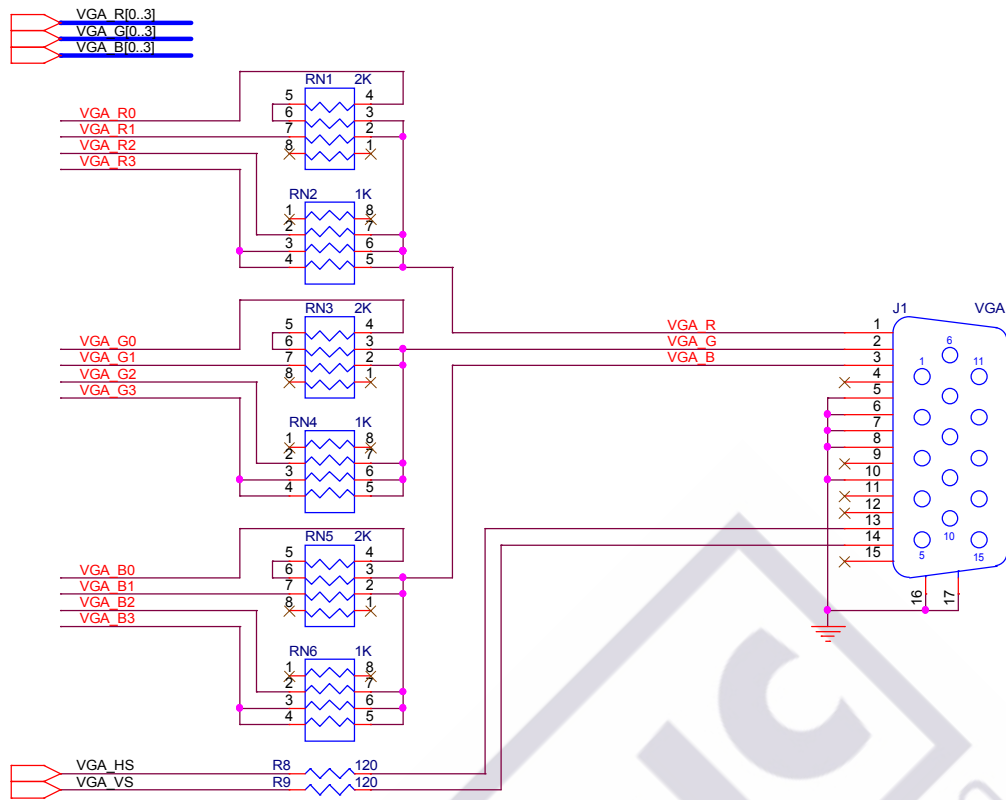

Copyright (c) 2007 by Terasic Technologies Inc. Taiwan. All rights reserved. No part of this schematic design may be reproduced, duplicated, or used without the prior written permission of Terasic.	
Title	
ALTEA DEO	
Size	Document Number
A	FLASH
Date:	Monday, September 27, 2010
Sheet	5 of 19
Rev	0A



 Copyright (c) 2007 by Terasic Technologies Inc. Taiwan. <small>All rights reserved.          No part of this schematic design may be reproduced, duplicated, or used without the prior written permission of Terasic.</small>	
<b>Title</b> ALTERA DE0	
<b>Size</b> A	<b>Document Number</b> 4 bit VGA Output
<b>Date:</b> Monday, September 27, 2010	
<b>Rev</b> 0A	
<b>Sheet</b> 6 <b>of</b> 19	

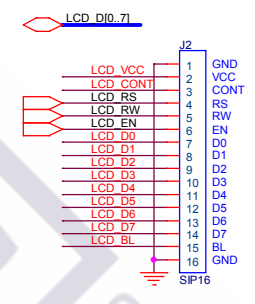
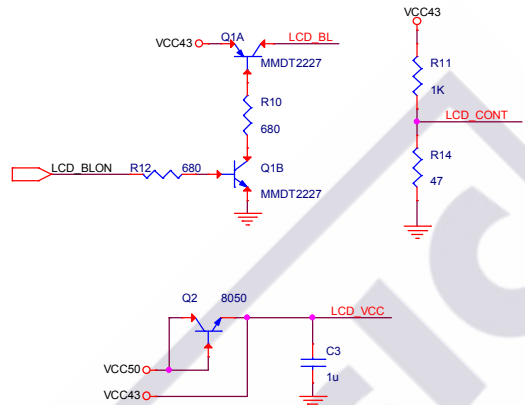
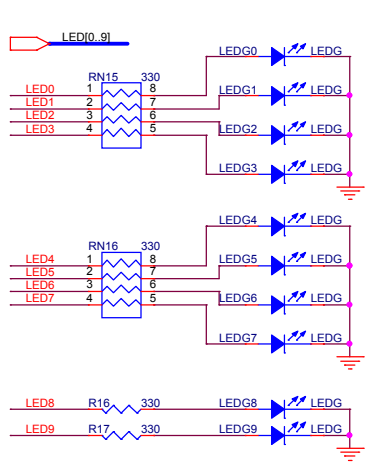
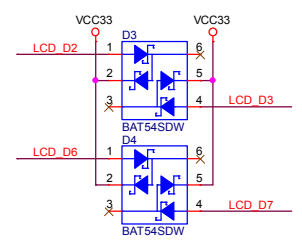
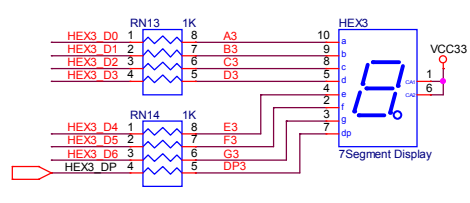
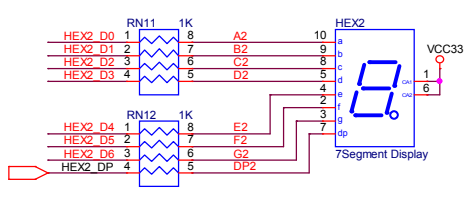
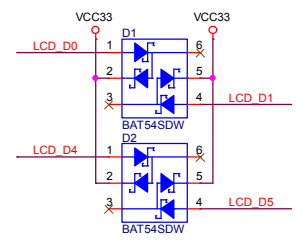
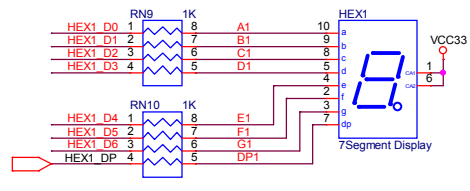
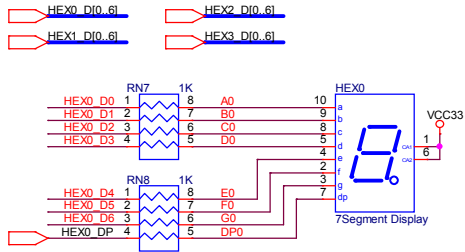

Copyright (c) 2007 by Terasic Technologies Inc. Taiwan. All rights reserved. No part of this schematic design may be reproduced, duplicated, or used without the prior written permission of Terasic.	
<b>Title</b> ALTERA DEO	
<b>Size</b> Custom	<b>Document Number</b> 7 SEGMENT, LED and LCD Connector
<b>Date</b> Monday, September 27, 2010	<b>Sheet</b> 7 of 19
<b>Rev</b> 0A	

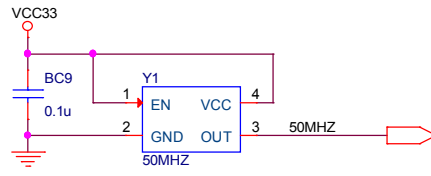

 Copyright (c) 2007 by Terasic Technologies Inc. Taiwan. All rights reserved. No part of this schematic design may be reproduced, duplicated, or used without the prior written permission of Terasic.	
<b>Title</b> ALTERA DE0	
<b>Size</b> A	<b>Document Number</b> CLOCK
<b>Date:</b> Monday, September 27, 2010	
Sheet 8 of 19	
Rev 0A	





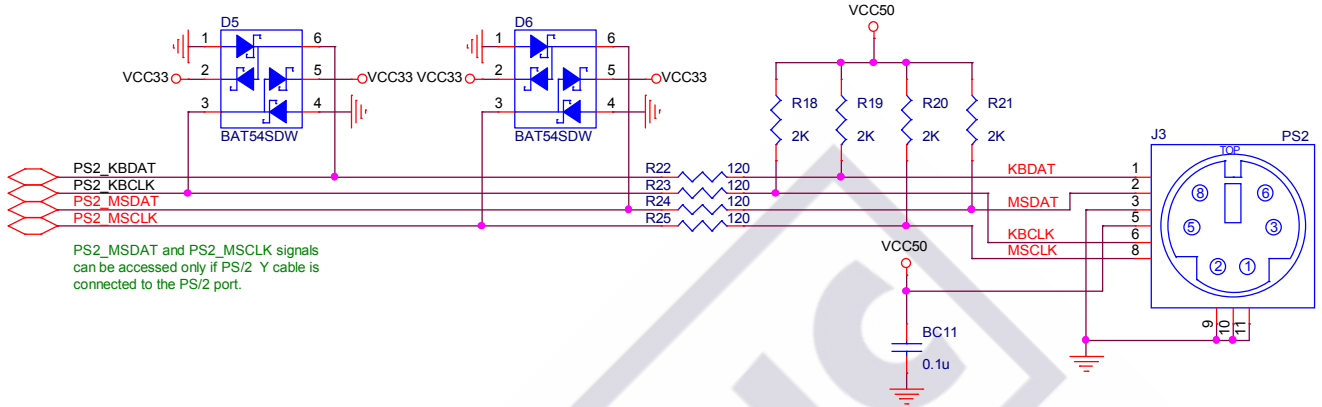
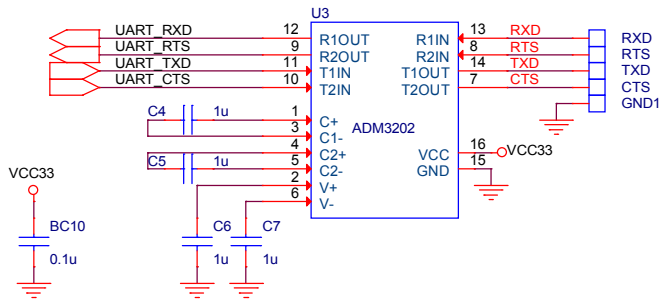

		Copyright (c) 2007 by Terasic Technologies Inc. Taiwan. All rights reserved. No part of this schematic design may be reproduced, duplicated, or used without the prior written permission of Terasic.
<b>Title</b> ALTERA DEO		
<b>Size</b> A	<b>Document Number</b> PS2 AND RS232	<b>Rev</b> 0A
<b>Date:</b> Monday, September 27, 2010		<b>Sheet</b> 9 of 19

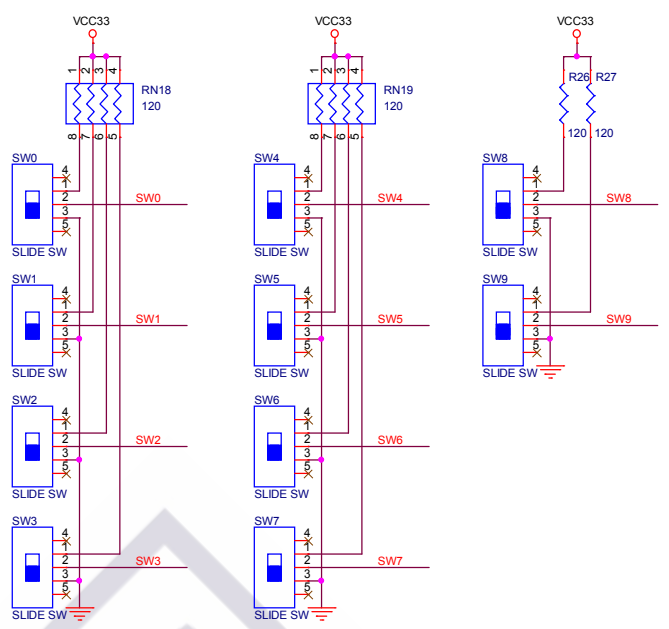
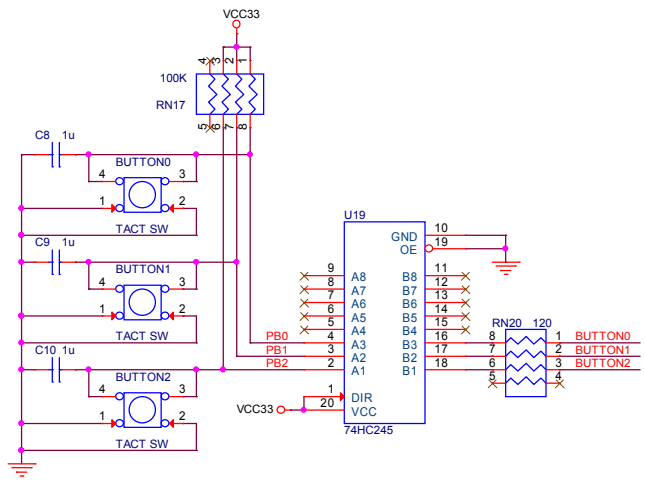

BUTTON0\_21  
SW0\_91

Copyright (c) 2007 by Terasic Technologies Inc. Taiwan. All rights reserved. No part of this schematic design may be reproduced, duplicated, or used without the prior written permission of Terasic.	
Title: <b>ALTERA DEO</b>	
Size: Custom	Document Number: Button and Switch
Date: Monday, September 27, 2010	Sheet 10 of 19
	Rev 0A

terasic  
www.terasic.com

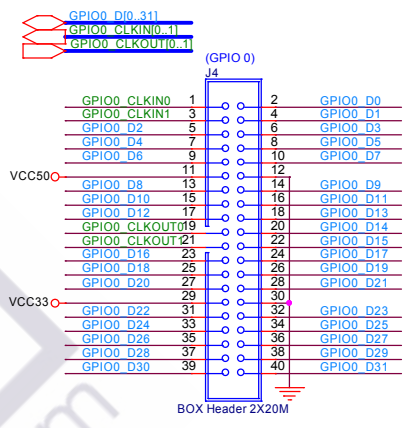
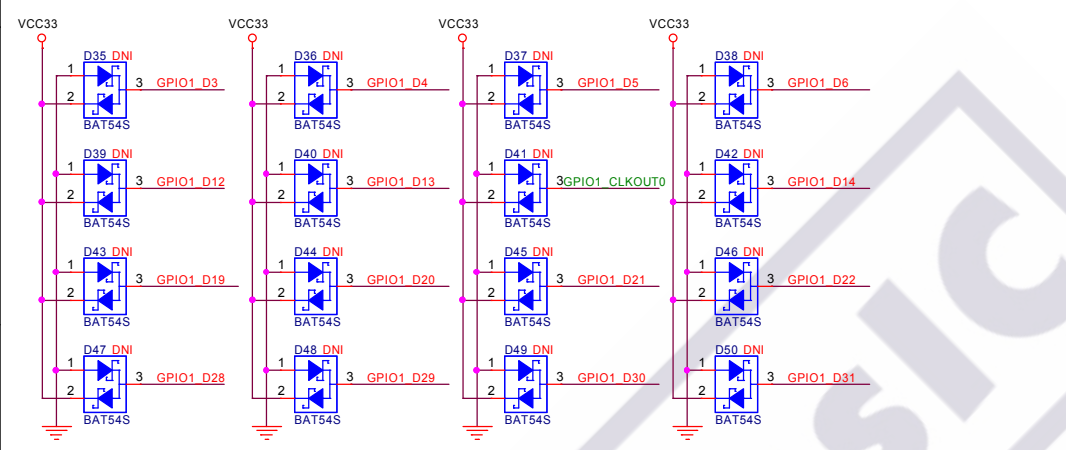
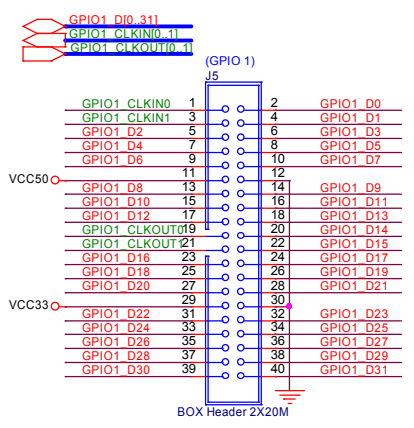
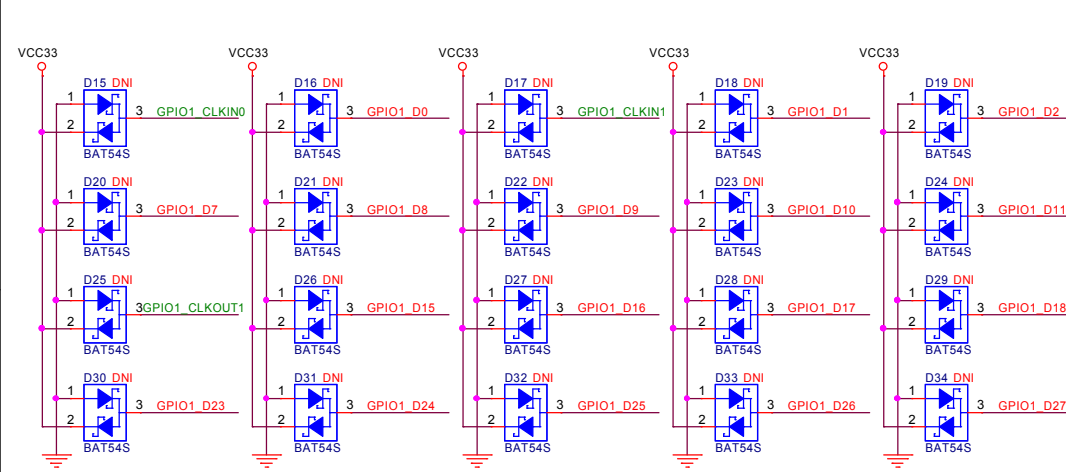

terasic  
www.terasic.com

Copyright (c) 2007 by Terasic Technologies Inc. Taiwan.  
All rights reserved.  
No part of this automatic design may be reproduced, duplicated, or used without the prior written permission of Terasic.

Title: **ALTERA DE0**

Size: Document Number  
CustomCONNECT

Date: Thursday, March 17, 2011

Sheet: 11 of 19

Rev: 0A

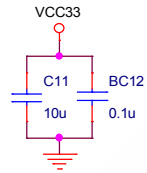
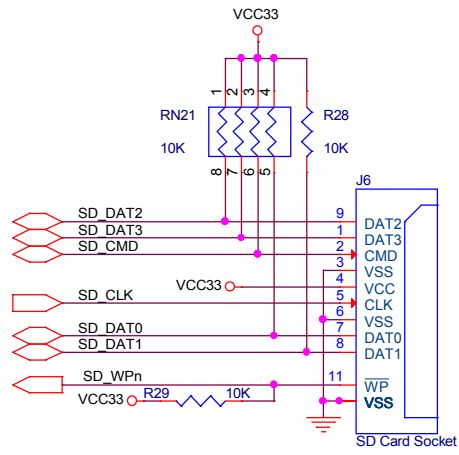

 Copyright (c) 2007 by Terasic Technologies Inc. Taiwan. All rights reserved. No part of this schematic design may be reproduced, duplicated, or used without the prior written permission of Terasic.	
<b>Title</b> ALTERA DE0	
<b>Size</b> A	<b>Document Number</b> SD Card Socket
<b>Date:</b> Monday, September 27, 2010	
Sheet 12 of 19	
Rev 0A	

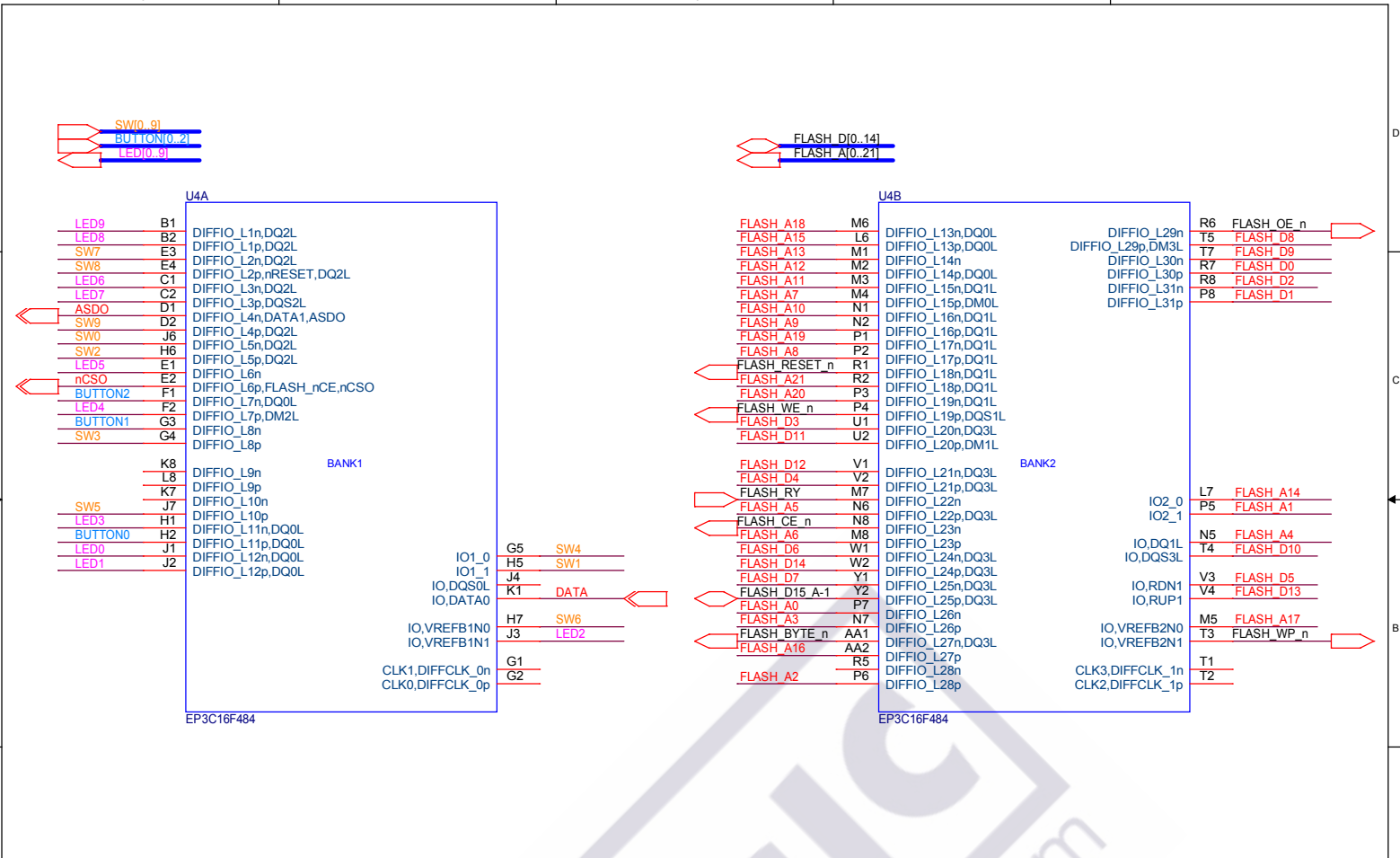

Copyright (c) 2007 by Terasic Technologies Inc. Terasic. All rights reserved. No part of this schematic design may be reproduced, duplicated, or used without the prior written permission of Terasic.

**ALTERA DE0**

Size: Custom Document Number: BANK1, BANK2 Rev: 0A

Date: Monday, September 27, 2010 Sheet: 13 of 19

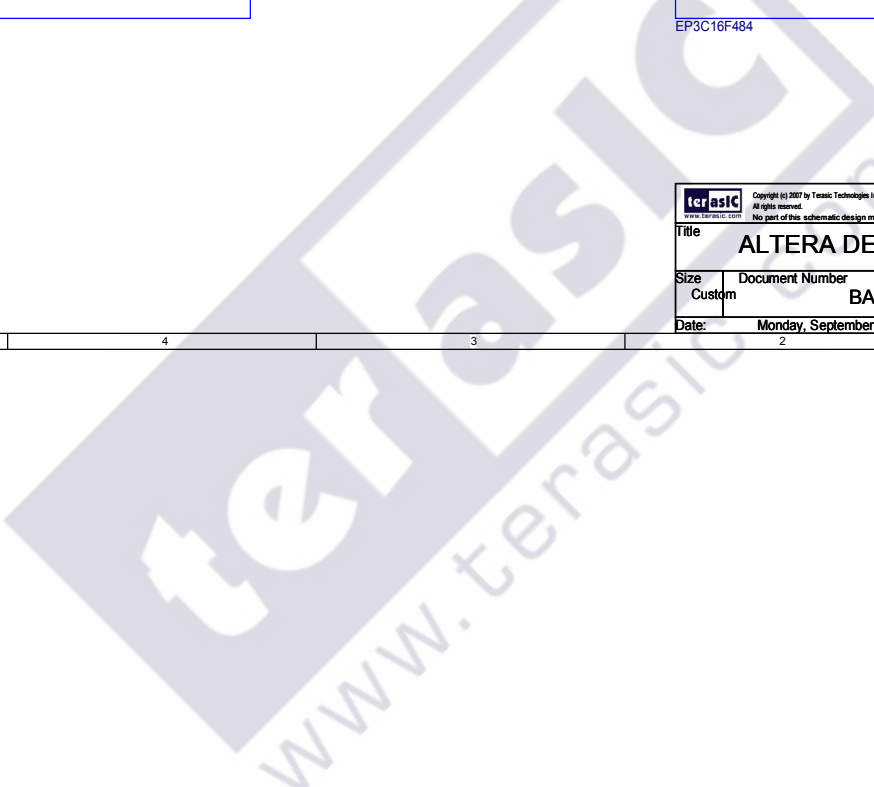

GPIO0\_DIO\_311  
 GPIO0\_CLKIN0\_11  
 GPIO0\_CLKOUT0\_11

GPIO1\_DIO\_311  
 GPIO1\_CLKIN0\_11  
 GPIO1\_CLKOUT0\_11

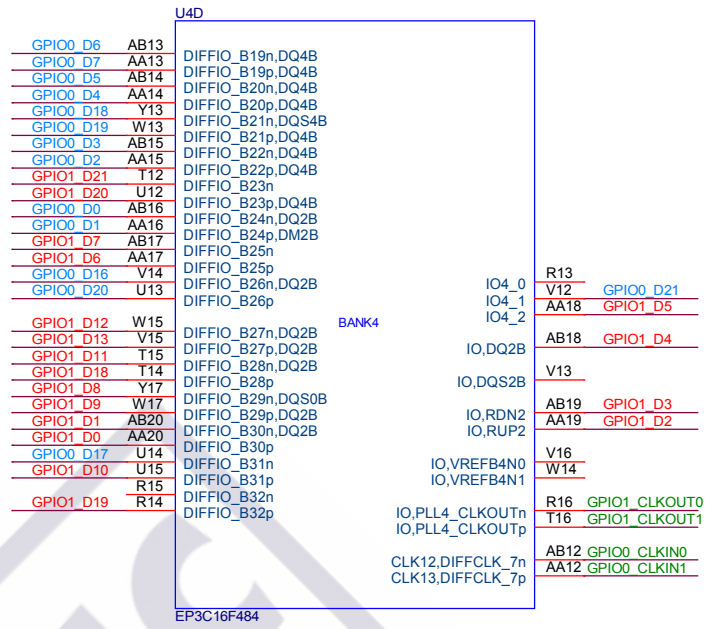
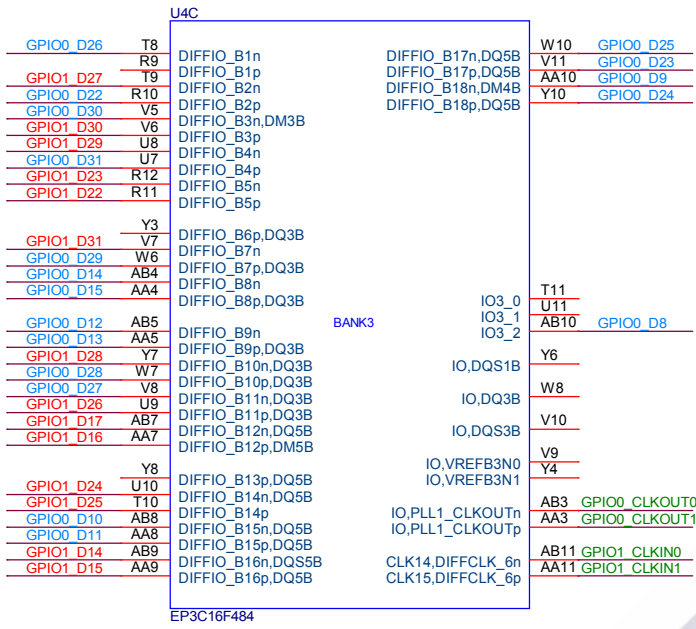

terasic Copyright (c) 2007 by Terasic Technologies Inc. Taiwan. All rights reserved. No part of this schematic design may be reproduced, duplicated, or used without the prior written permission of Terasic.

Title: **ALTERA DE0**

Size A: Document Number: **BANK3, BANK4** Rev 0A

Date: Monday, September 27, 2010 Sheet 14 of 19

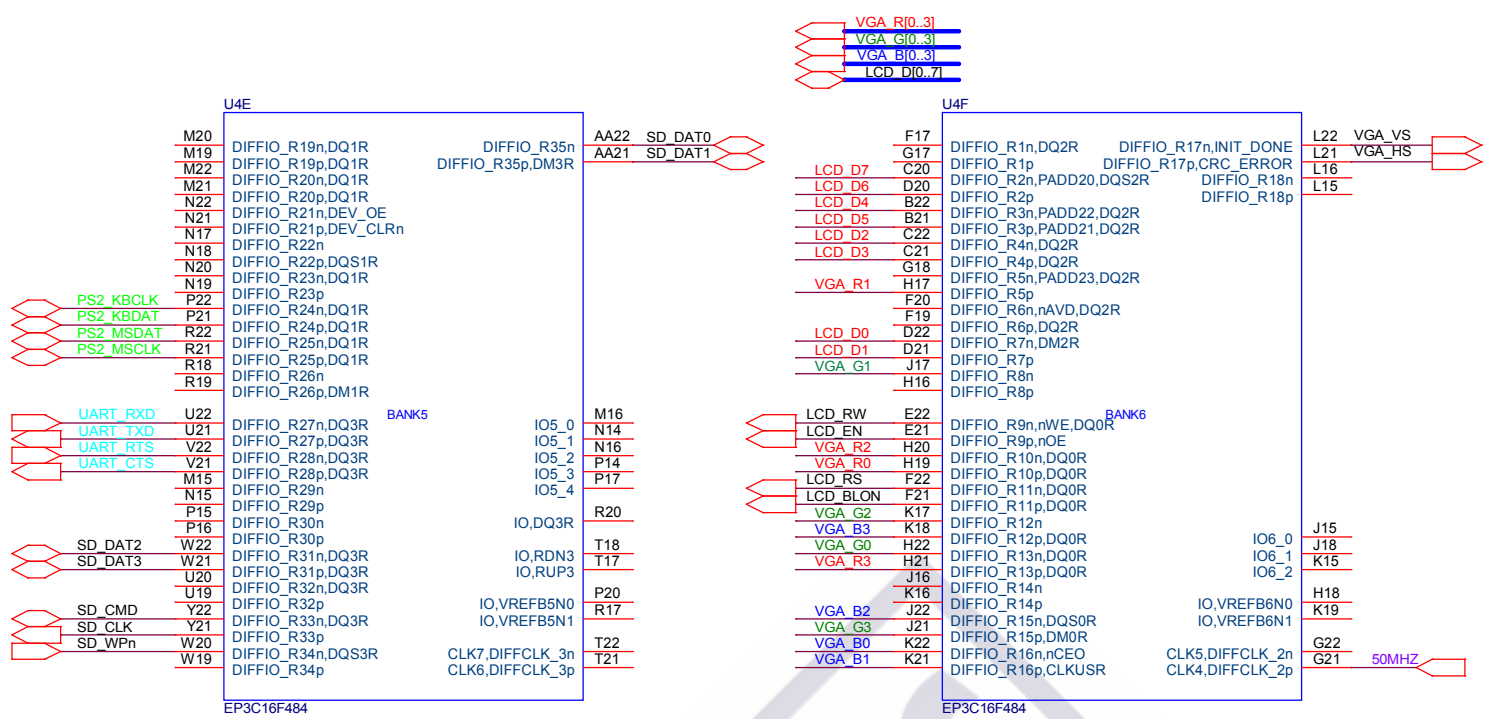

terasic Copyright (c) 2007 by Terasic Technologies Inc. Taiwan. All rights reserved. No part of this schematic design may be reproduced, duplicated, or used without the prior written permission of Terasic.

**Title** ALTERA DEO

**Size A** Document Number **BANK5, BANK6** **Rev 0A**

**Date:** Monday, September 27, 2010 **Sheet** 15 **of** 19

HEX0\_D10\_6I  
 HEX1\_D10\_6I  
 HEX2\_D10\_6I  
 HEX3\_D10\_6I

DRAM\_D10\_15I  
 DRAM\_A10\_12I  
 DRAM\_DQM0\_1I  
 DRAM\_BA10\_1I

U4G

U4H

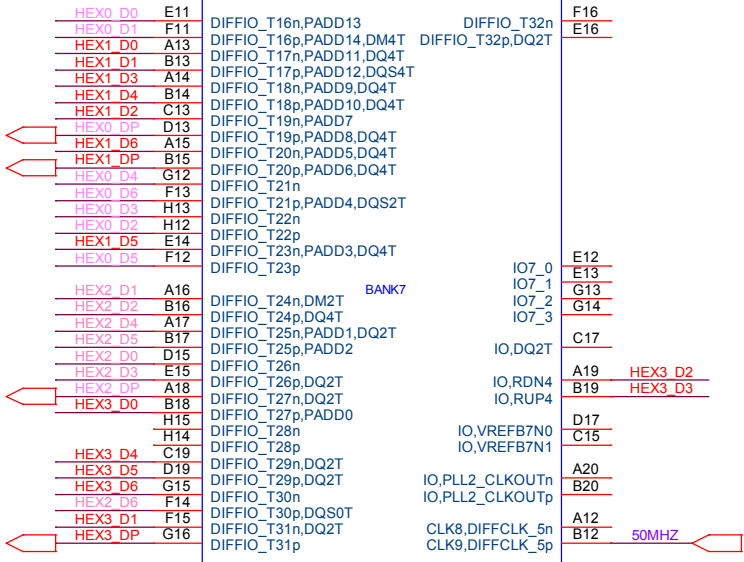

EP3C16F484

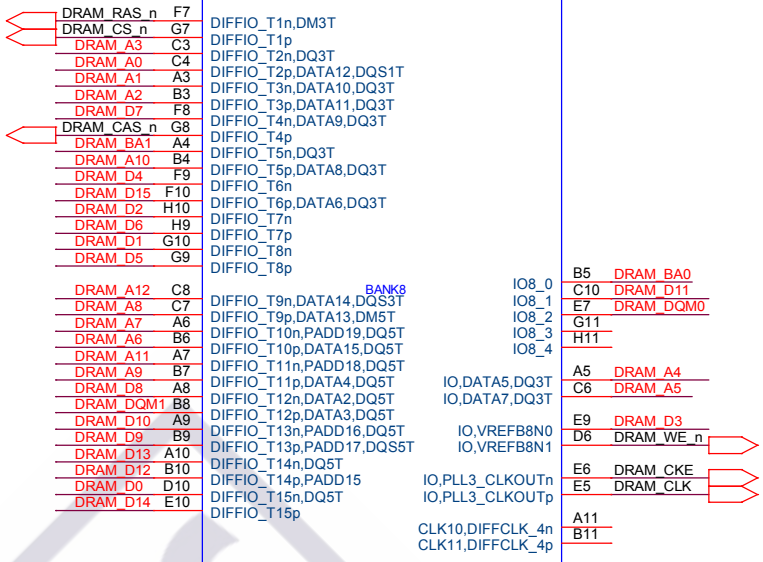

EP3C16F484

terasic Copyright (c) 2007 by Terasic Technologies Inc. Taiwan. All rights reserved. No part of this schematic design may be reproduced, duplicated, or used without the prior written permission of Terasic.

**Title** ALTERA DEO

Size A	Document Number	Rev 0A
	<b>BANK7, BANK8</b>	

Date: Monday, September 27, 2010 Sheet 16 of 19



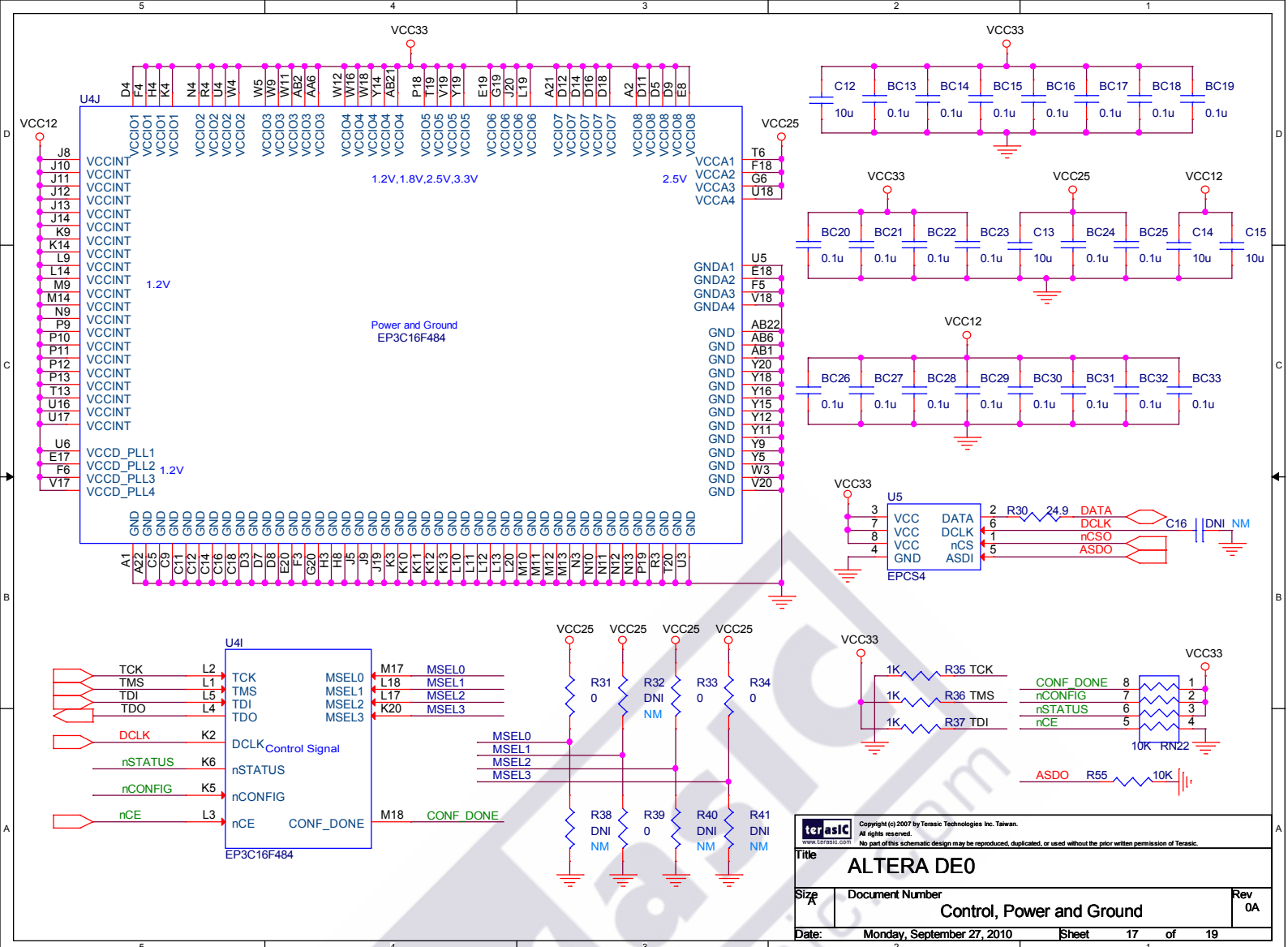

Copyright (c) 2007 by Terasic Technologies Inc. Taiwan. All rights reserved. No part of this schematic design may be reproduced, duplicated, or used without the prior written permission of Terasic.	
<b>Title</b> ALTERA DE0	
<b>Size</b> A	<b>Document Number</b>
<b>Control, Power and Ground</b>	
<b>Date:</b> Monday, September 27, 2010	<b>Sheet</b> 17 of 19
	<b>Rev</b> 0A

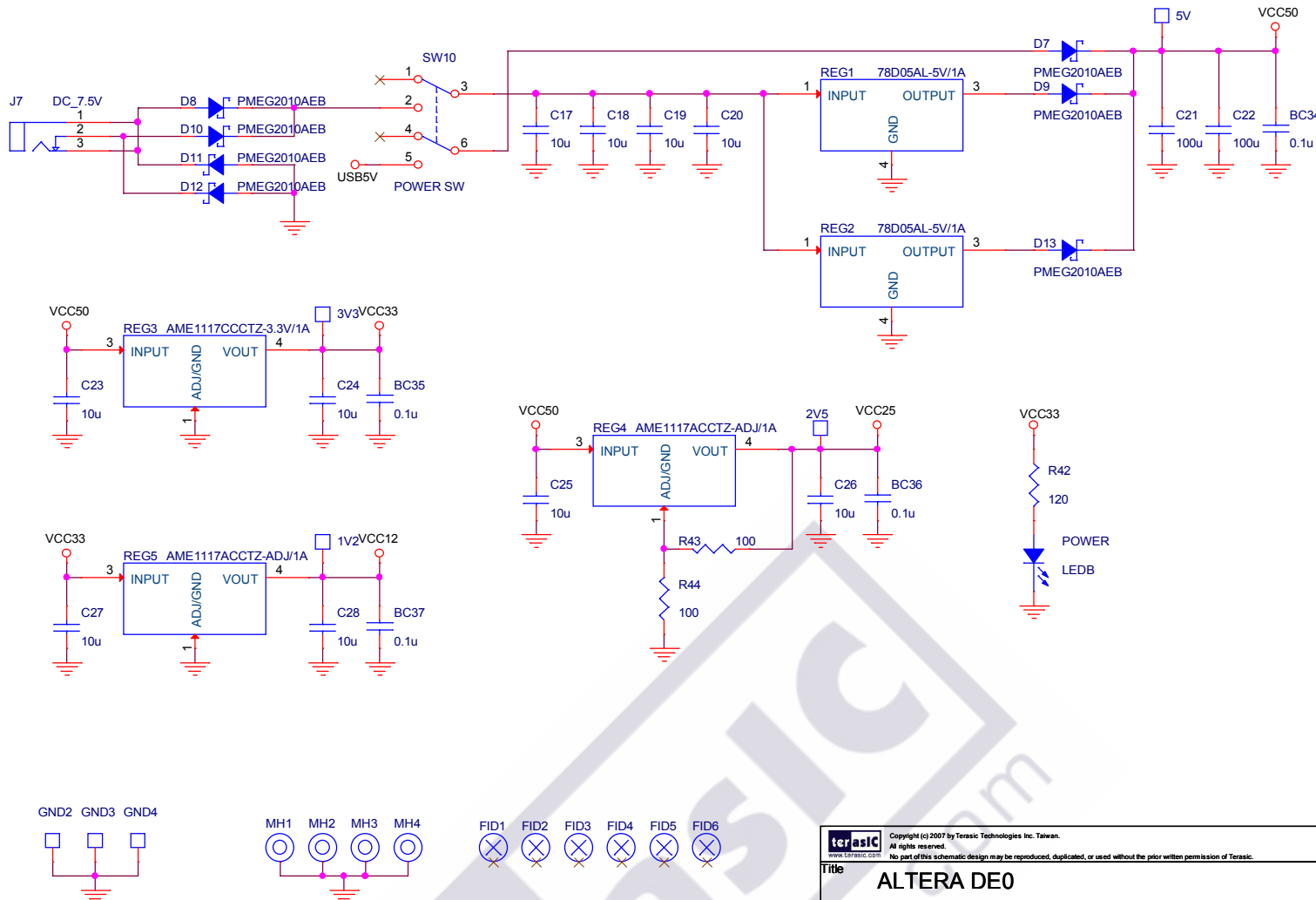

Copyright (c) 2007 by Terasic Technologies Inc. Taiwan. <small>All rights reserved.          No part of this schematic design may be reproduced, duplicated, or used without the prior written permission of Terasic.</small>	
<b>Title</b> ALTERA DE0	
<b>Size</b> A	<b>Document Number</b> POWER
<b>Date:</b> Monday, September 27, 2010	
<b>Sheet</b> 18 <b>of</b> 19	
<b>Rev</b> 0A	

