

# ОСНОВИ РАЧУНАРСКЕ ТЕХНИКЕ

*PS/2*

# Садржај

- [Плочица](#)
- [Пинови](#)
- [Протокол](#)
- [Главна шема](#)
- [Уређај Р](#)
- [Уређај UB](#)
- [Уређај UA](#)
- [Детектор узлазне ивице](#)
- [Дибансер](#)
- [Једноразредни регистар](#)

# Плочица

- DE0

PS/2 Connector

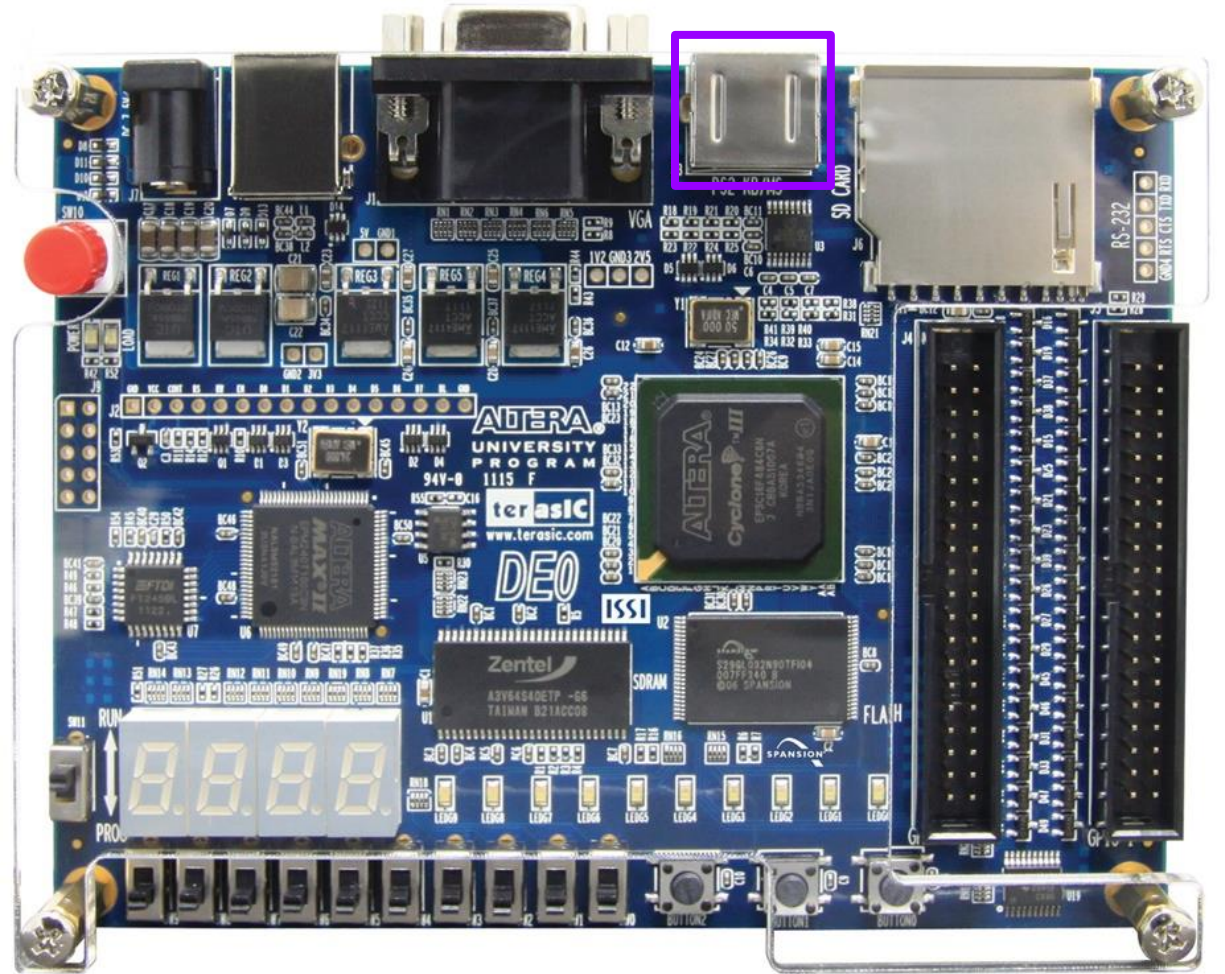
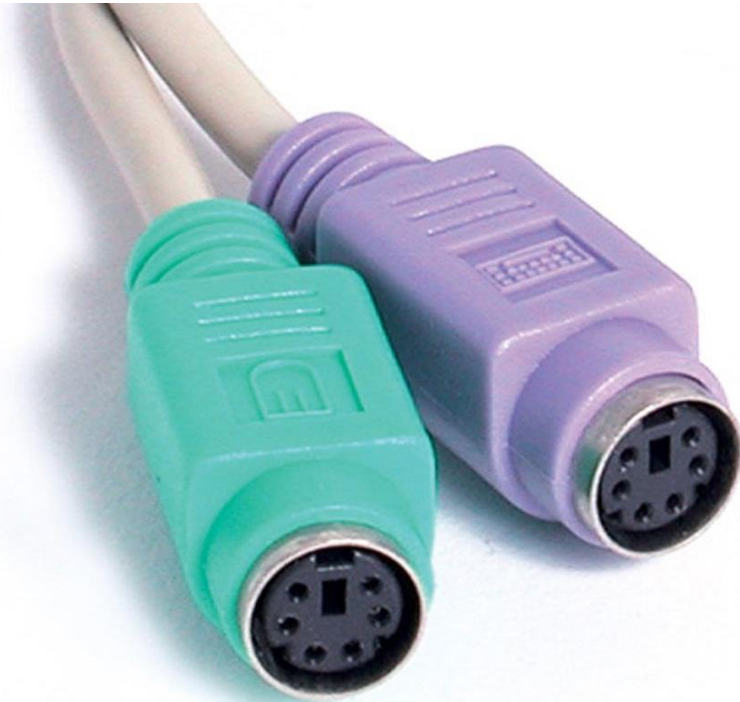

# Плочица

- DE0-CV

PS/2 Connector

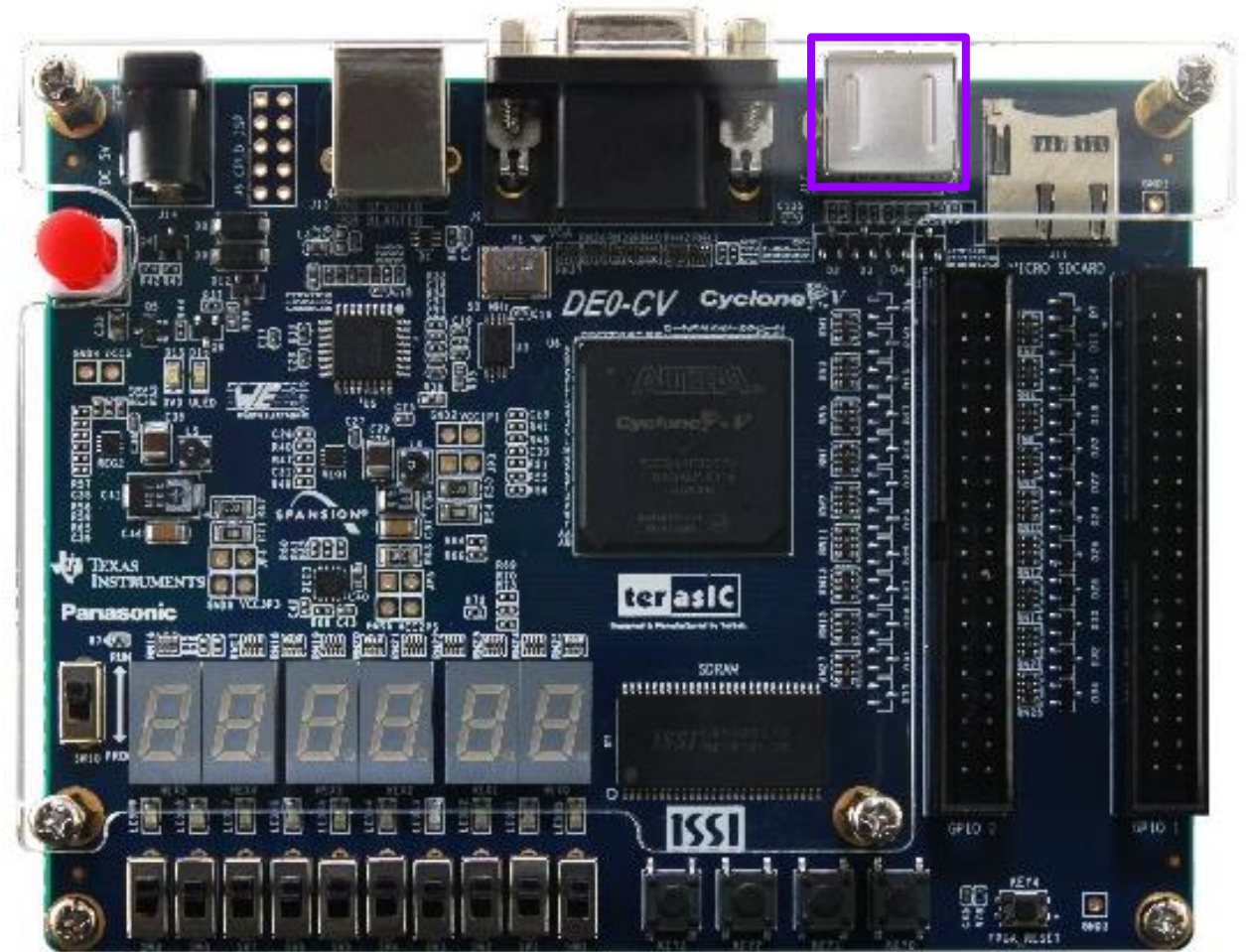
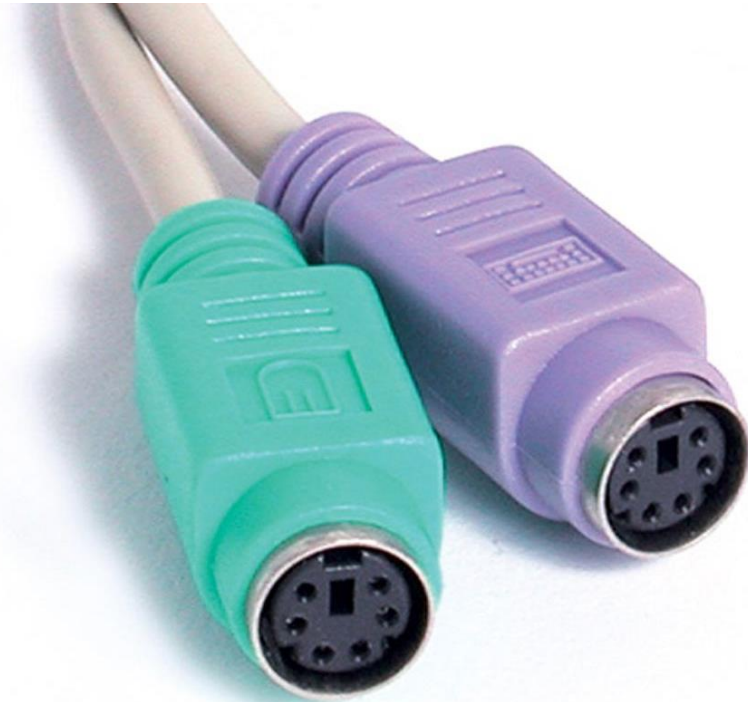

# ПИНОВИ

- PS/2

Cyclone III		Cyclone V	
PS2_KBCLK	PIN_P22	PS2_CLK	PIN_D3
PS2_KBDAT	PIN_P21	PS2_DAT	PIN_G2

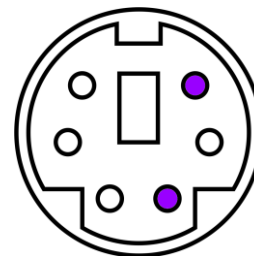

# Протокол

- Scan Code Set 2
- Make Code (притиснут тастер) -> један или више бајтова
- Break Code (отпуштен тастер) -> у Make Code се као други бајт умеће F0

Key 'A'	
Make Code	1C
Break Code	F0 1C

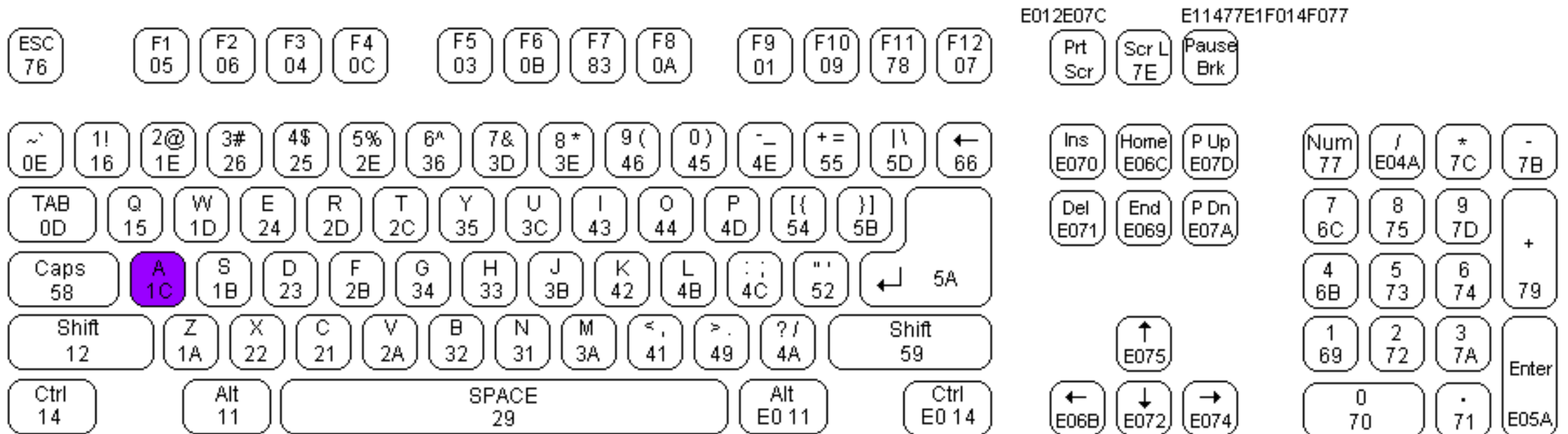

# Протокол

- Серијско слање података (10KHz-16.7KHz)
- Сваки бајт као пакет од 11 бита

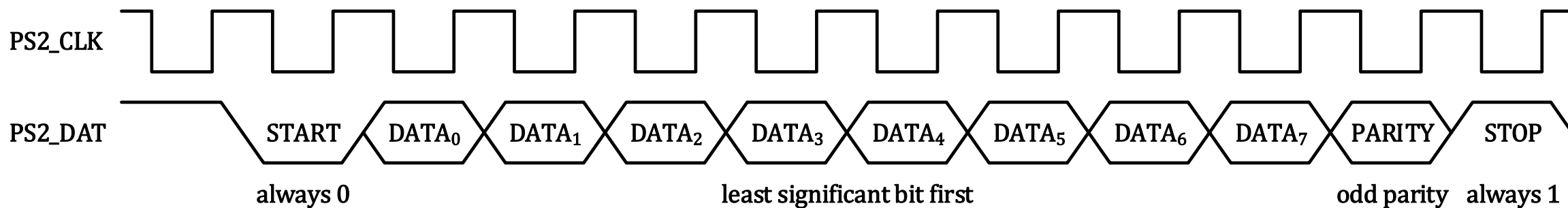

Key	Action	Scan Code	Packet	Sending
-	-	-	-	...111111111111111111111111...
A	Pressed	1C	0 00011100 0 1	...10001110000...
A	Released	F0 1C	1111 0000 0001 1100	...1000111000011000011110...
			0 11110000 1 1	
			0 00011100 0 1	

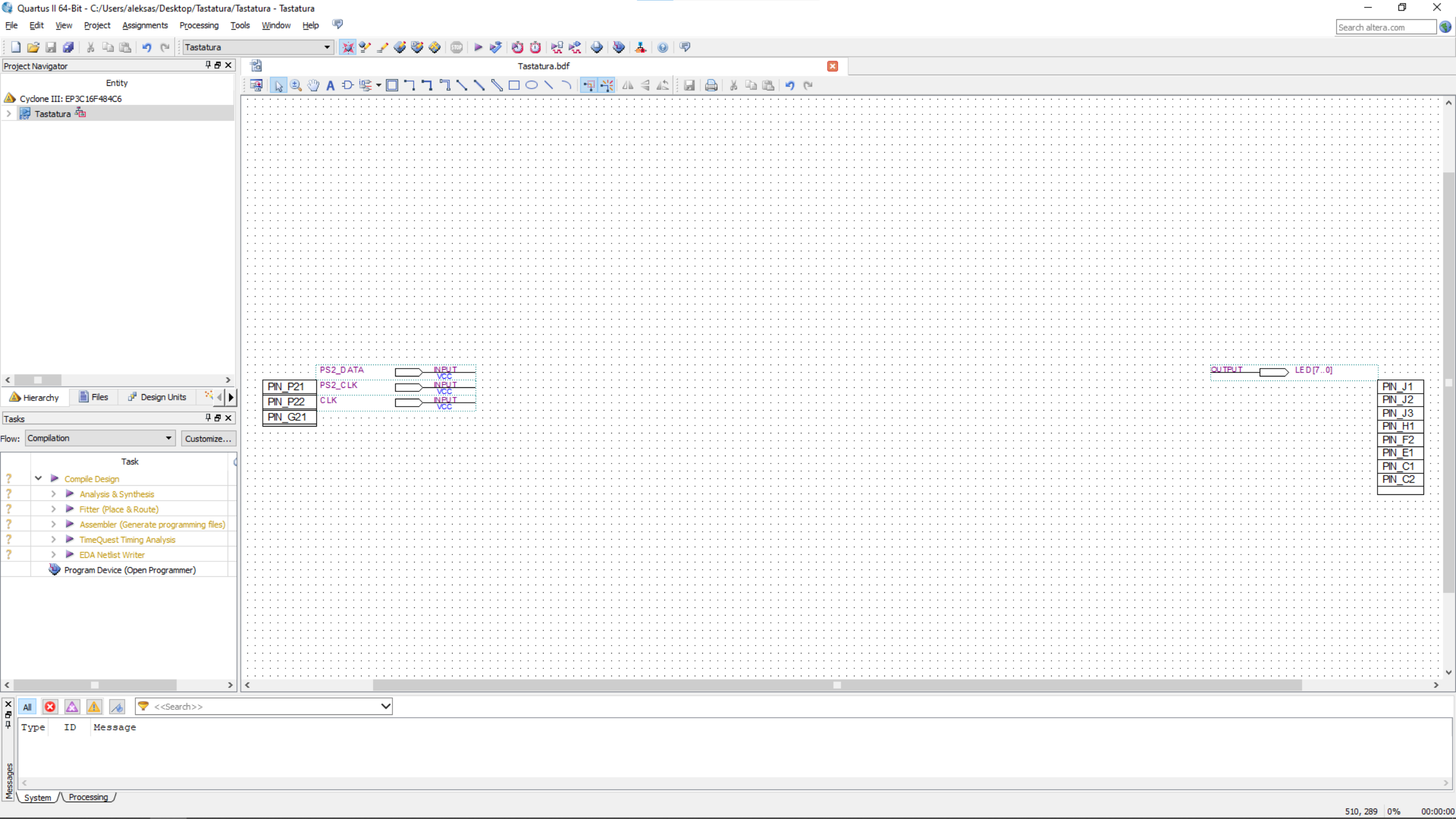

Project Navigator

Entity

- Cydone III: EP3C16F484C6
- Tastatura

Tastatura.bdf

Toolbar with various design tools like selection, zoom, and undo.

Hierarchy

Files

Design Units

Tasks

Flow: Compilation

Customize...

- Task
- Compile Design
  - Analysis & Synthesis
  - Fitter (Place & Route)
  - Assembler (Generate programming files)
  - TimeQuest Timing Analysis
  - EDA Netlist Writer
- Program Device (Open Programmer)

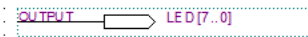
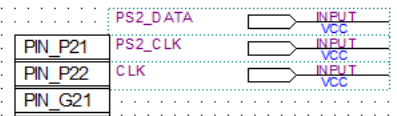

- PIN\_J1
- PIN\_J2
- PIN\_J3
- PIN\_H1
- PIN\_F2
- PIN\_E1
- PIN\_C1
- PIN\_C2

Messages

All

<<Search>>

Type	ID	Message
------	----	---------



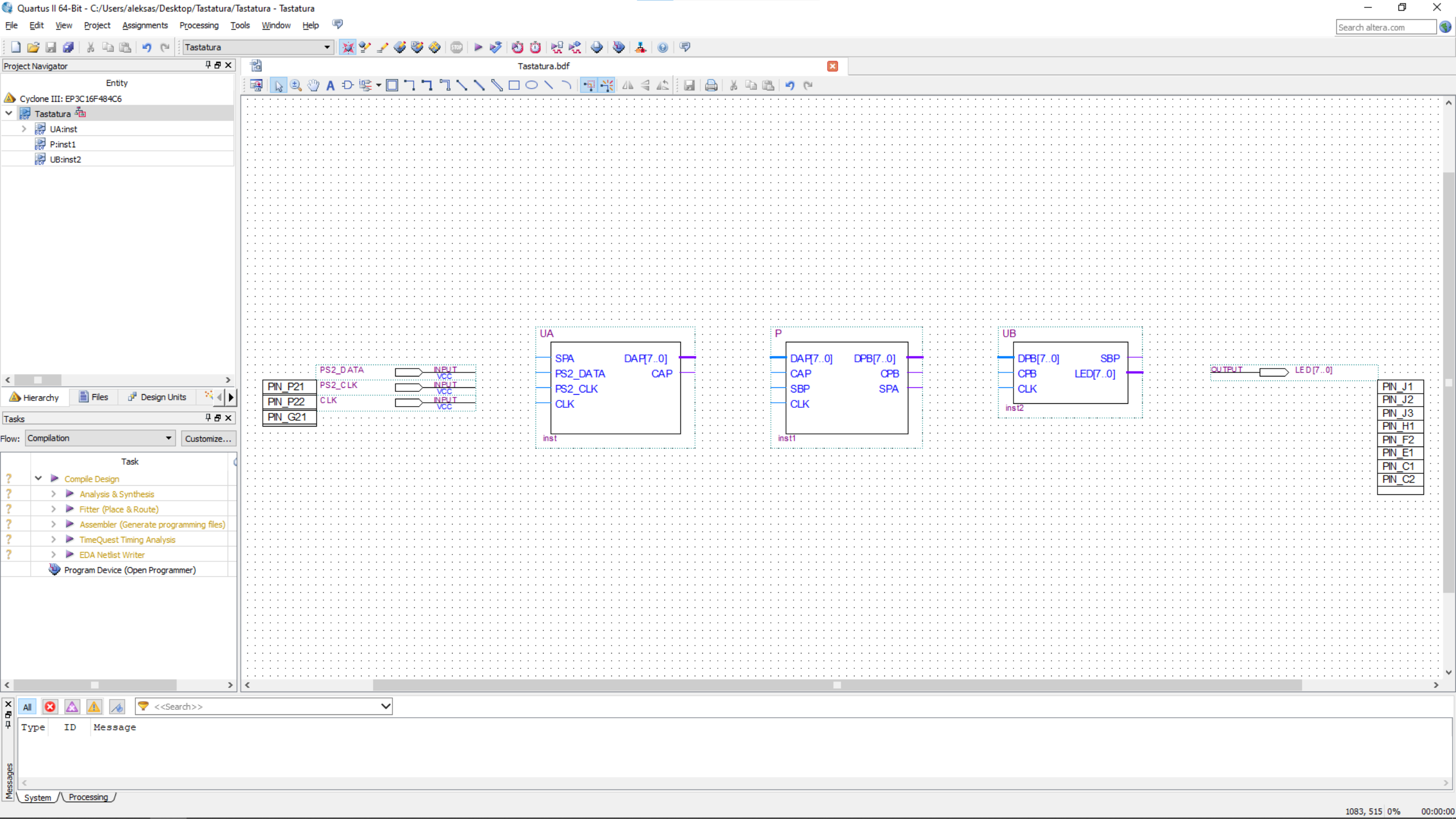

Project Navigator

Entity

- Cyclone III: EP3C16F484C6
  - Tastatura
    - UA:inst
    - P:inst1
    - UB:inst2

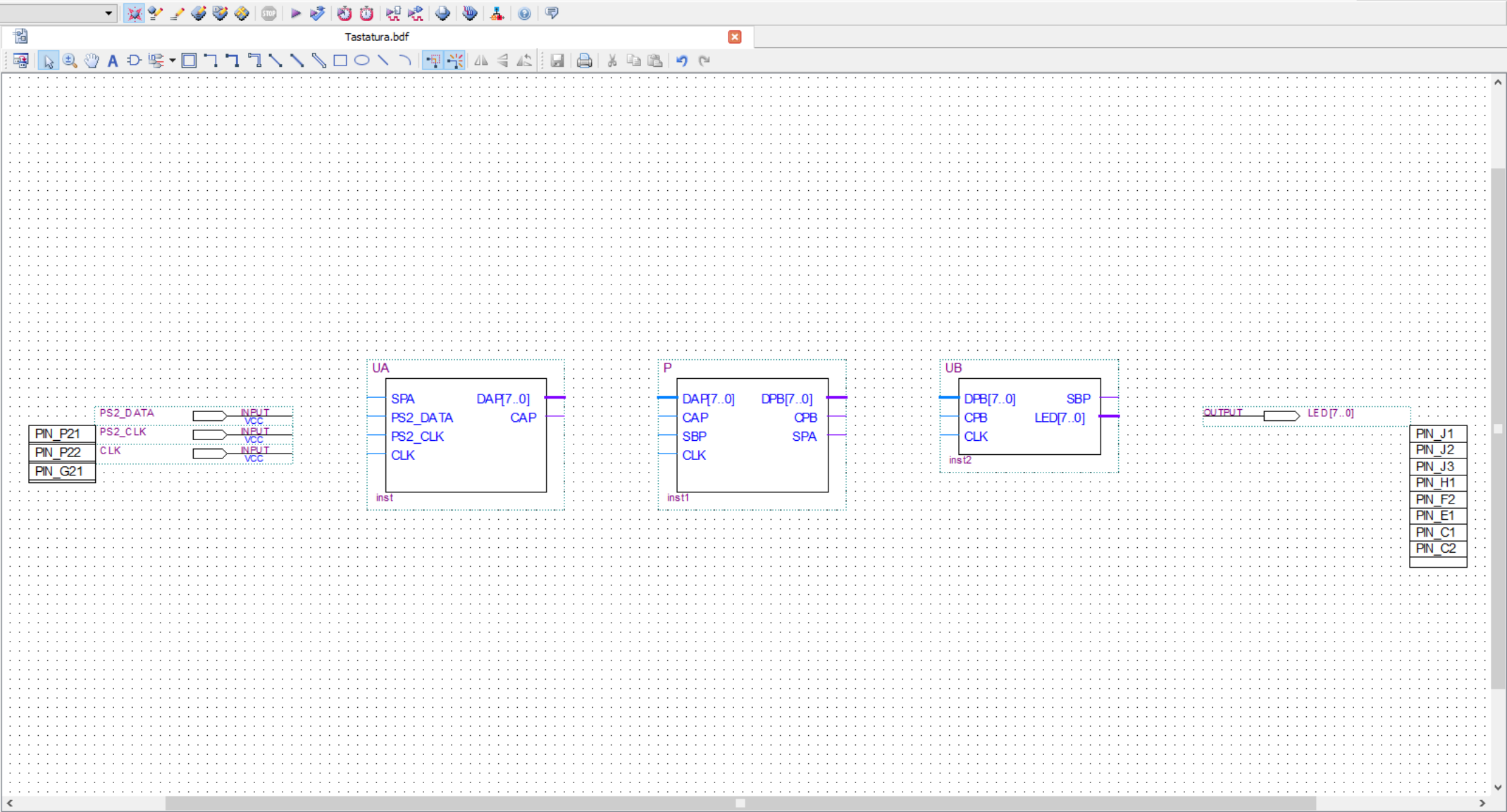

Hierarchy, Files, Design Units

Tasks

Flow: Compilation

Customize...

Task

- Compile Design
  - Analysis & Synthesis
  - Fitter (Place & Route)
  - Assembler (Generate programming files)
  - TimeQuest Timing Analysis
  - EDA Netlist Writer
- Program Device (Open Programmer)

All, Search

Messages

Type	ID	Message
System	Processing	

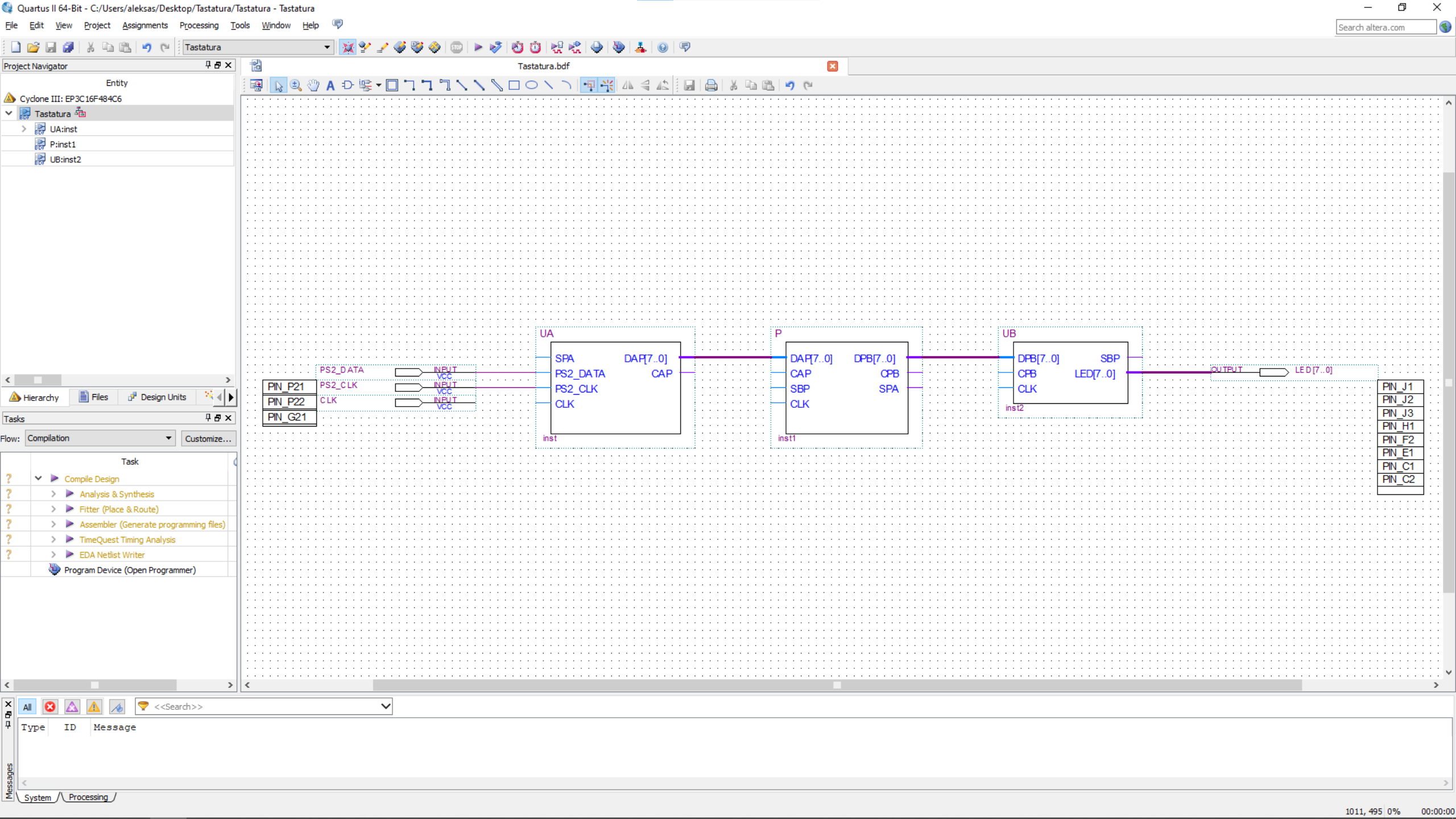

Project Navigator

Entity

- Cydome III: EP3C16F484C6
  - Tastatura
    - UA:inst
    - P:inst1
    - UB:inst2

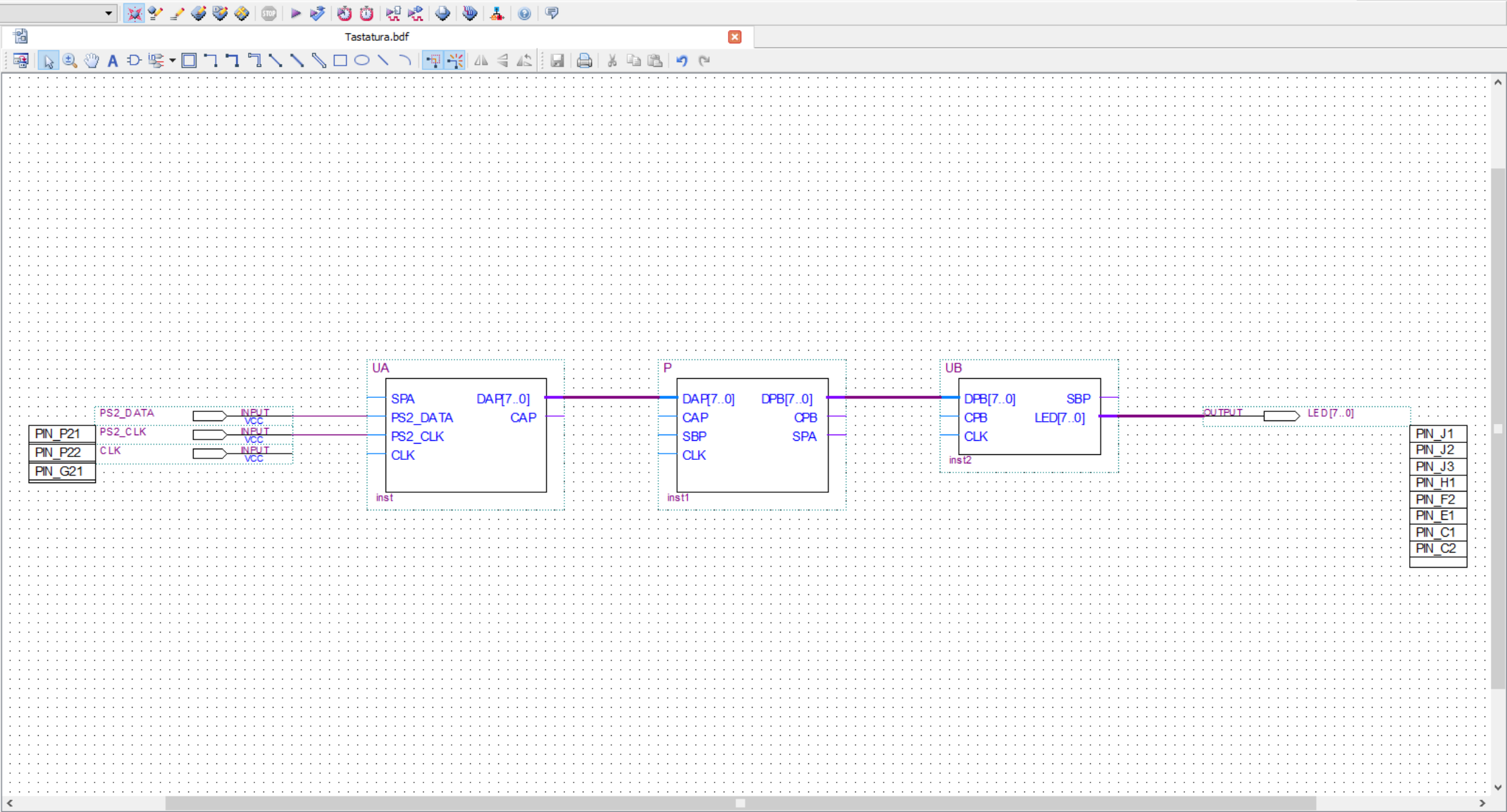

Hierarchy

Files

Design Units

Tasks

Flow: Compilation

Task

- Compile Design
  - Analysis & Synthesis
  - Fitter (Place & Route)
  - Assembler (Generate programming files)
  - TimeQuest Timing Analysis
  - EDA Netlist Writer
- Program Device (Open Programmer)

All

<<Search>>

Type	ID	Message

Project Navigator

Entity

- Cydone III: EP3C16F484C6
  - Tastatura
    - UA:inst
    - P:inst1
    - UB:inst2

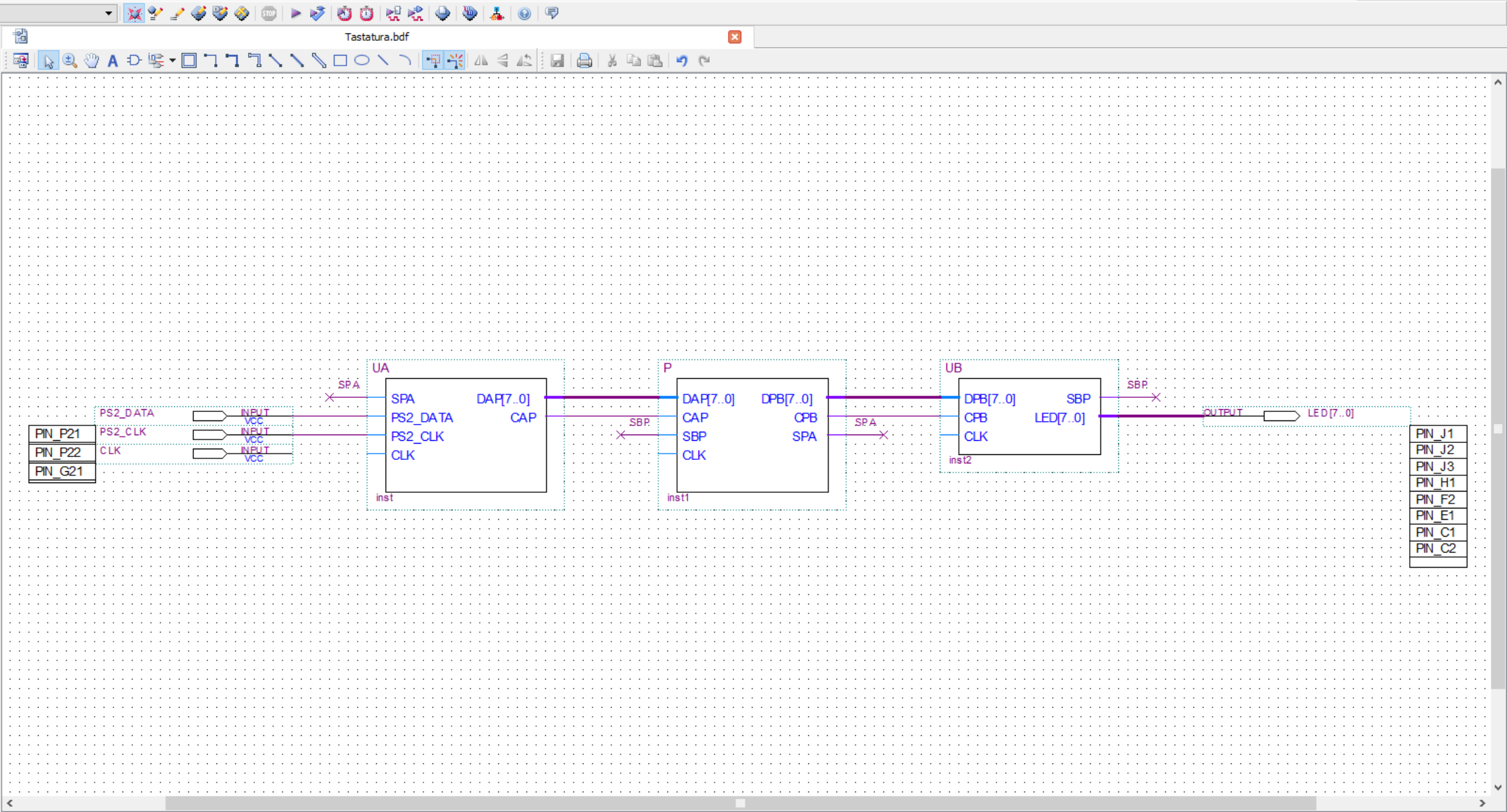

Hierarchy

Files

Design Units

Tasks

Flow: Compilation

Task

- Compile Design
  - Analysis & Synthesis
  - Fitter (Place & Route)
  - Assembler (Generate programming files)
  - TimeQuest Timing Analysis
  - EDA Netlist Writer
- Program Device (Open Programmer)

Messages

All

Type ID Message

System Processing

Project Navigator

Entity

- Cydone III: EP3C16F484C6
  - Tastatura
    - UA:inst
    - P:inst1
    - UB:inst2

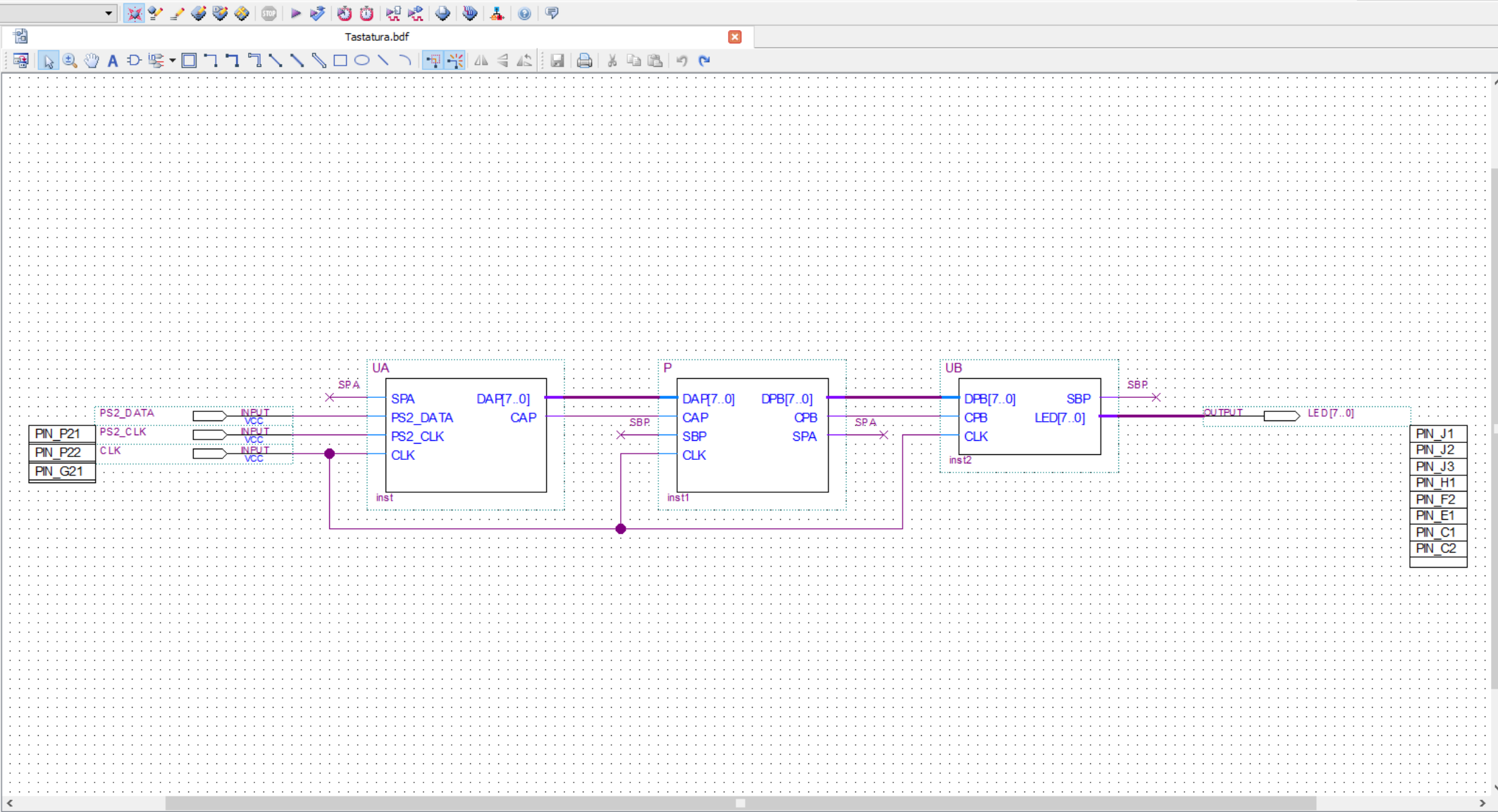

Tasks

Flow: Compilation

Task
Compile Design
Analysis & Synthesis
Fitter (Place & Route)
Assembler (Generate programming files)
TimeQuest Timing Analysis
EDA Netlist Writer
Program Device (Open Programmer)

Messages

Type	ID	Message
System		Processing

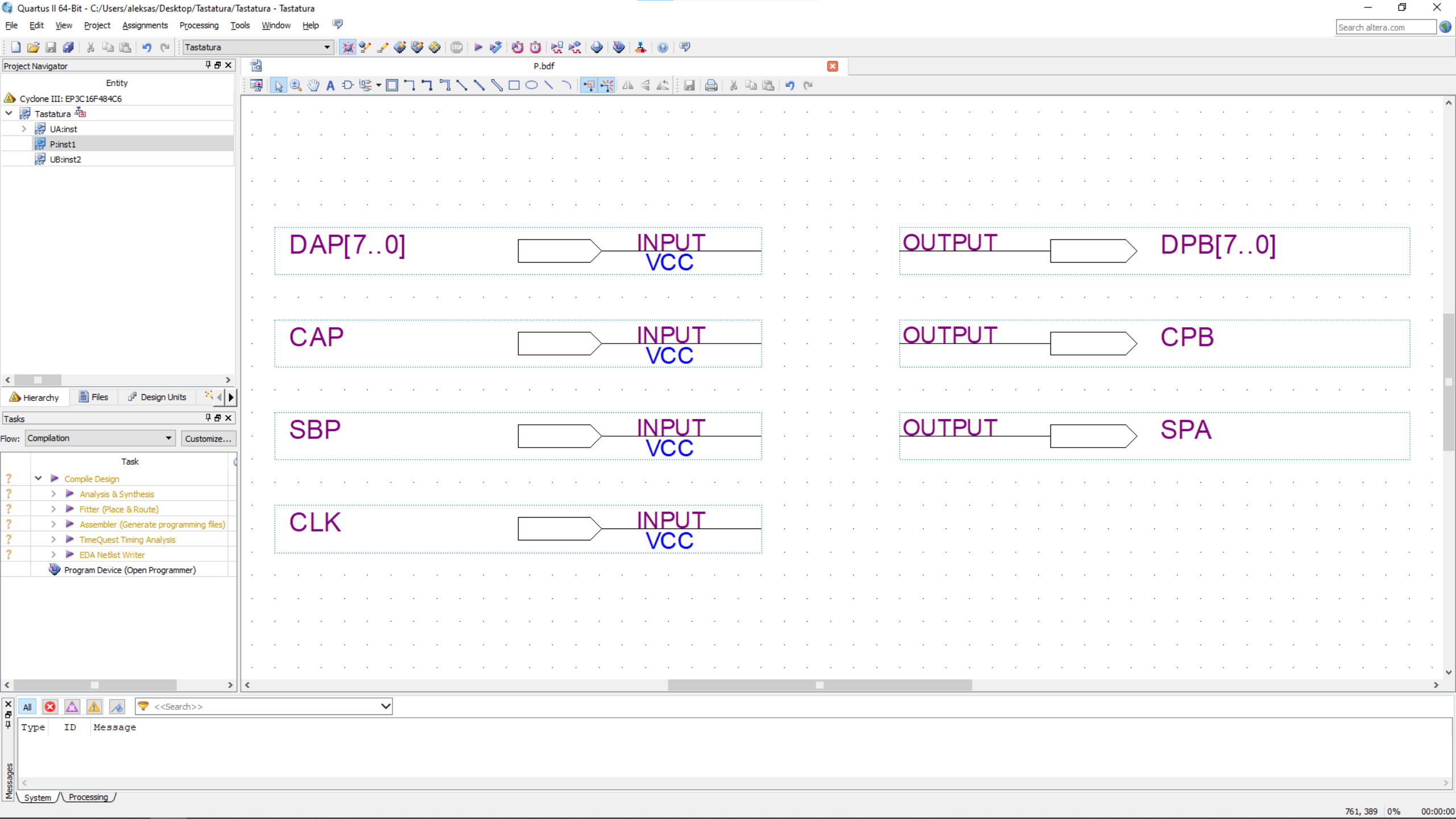

DAP[7..0]

INPUT  
VCC

OUTPUT

DPB[7..0]

CAP

INPUT  
VCC

OUTPUT

CPB

SBP

INPUT  
VCC

OUTPUT

SPA

CLK

INPUT  
VCC

All <<Search>>

Type	ID	Message
------	----	---------

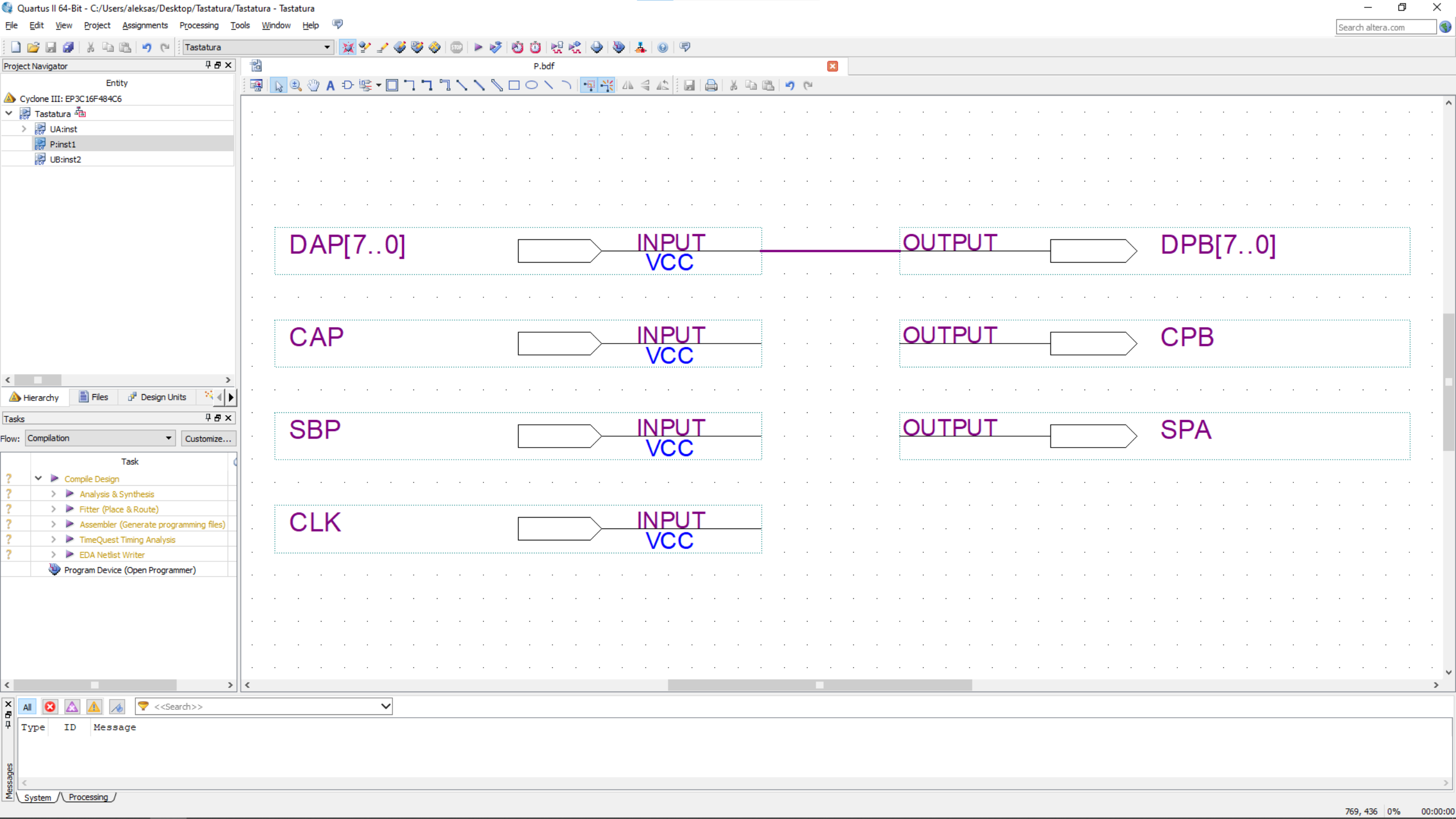

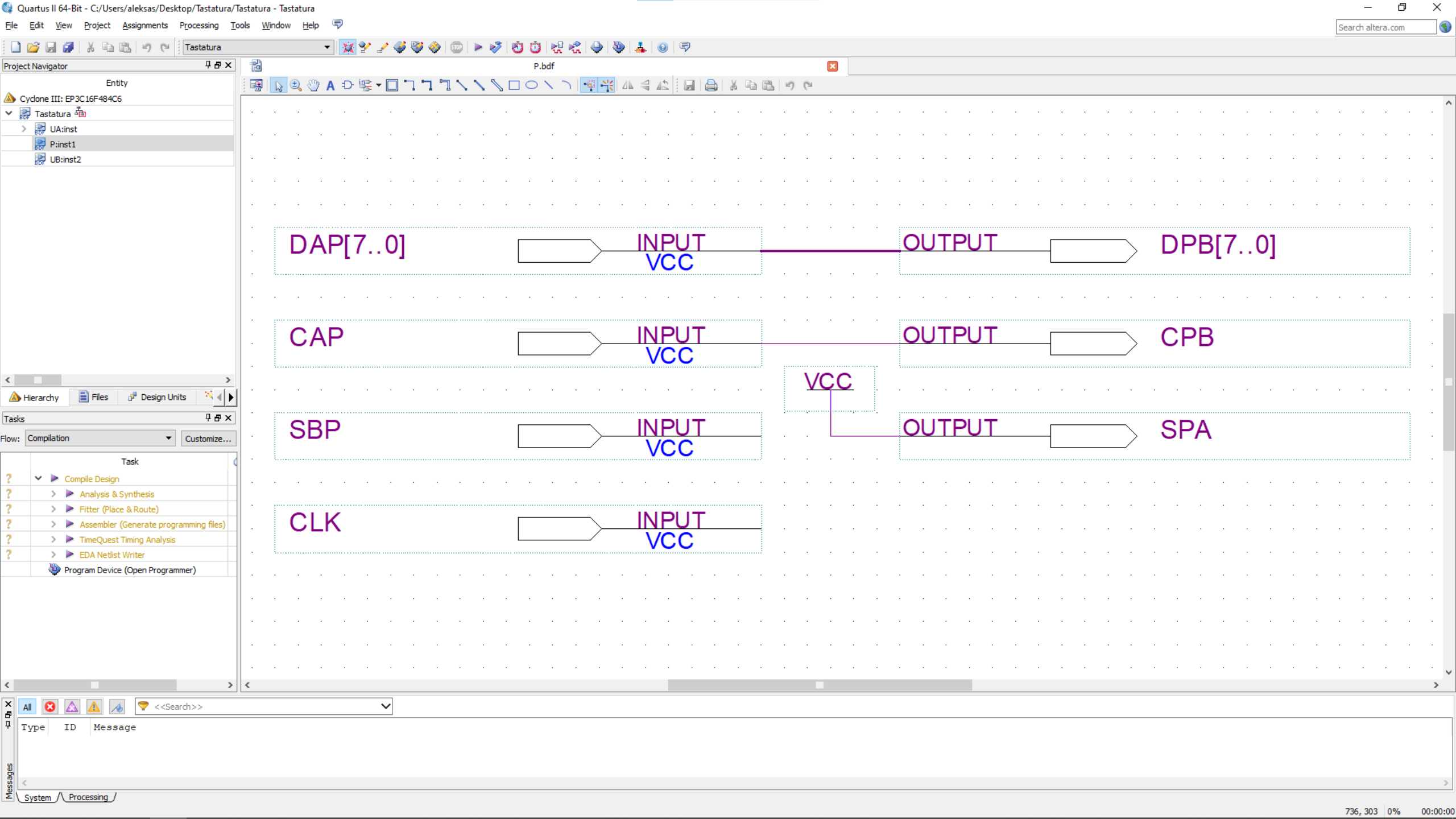

Project Navigator

Entity

- Cyclone III: EP3C16F484C6
  - Tastatura
    - UA:inst
    - P:inst1
    - UB:inst2

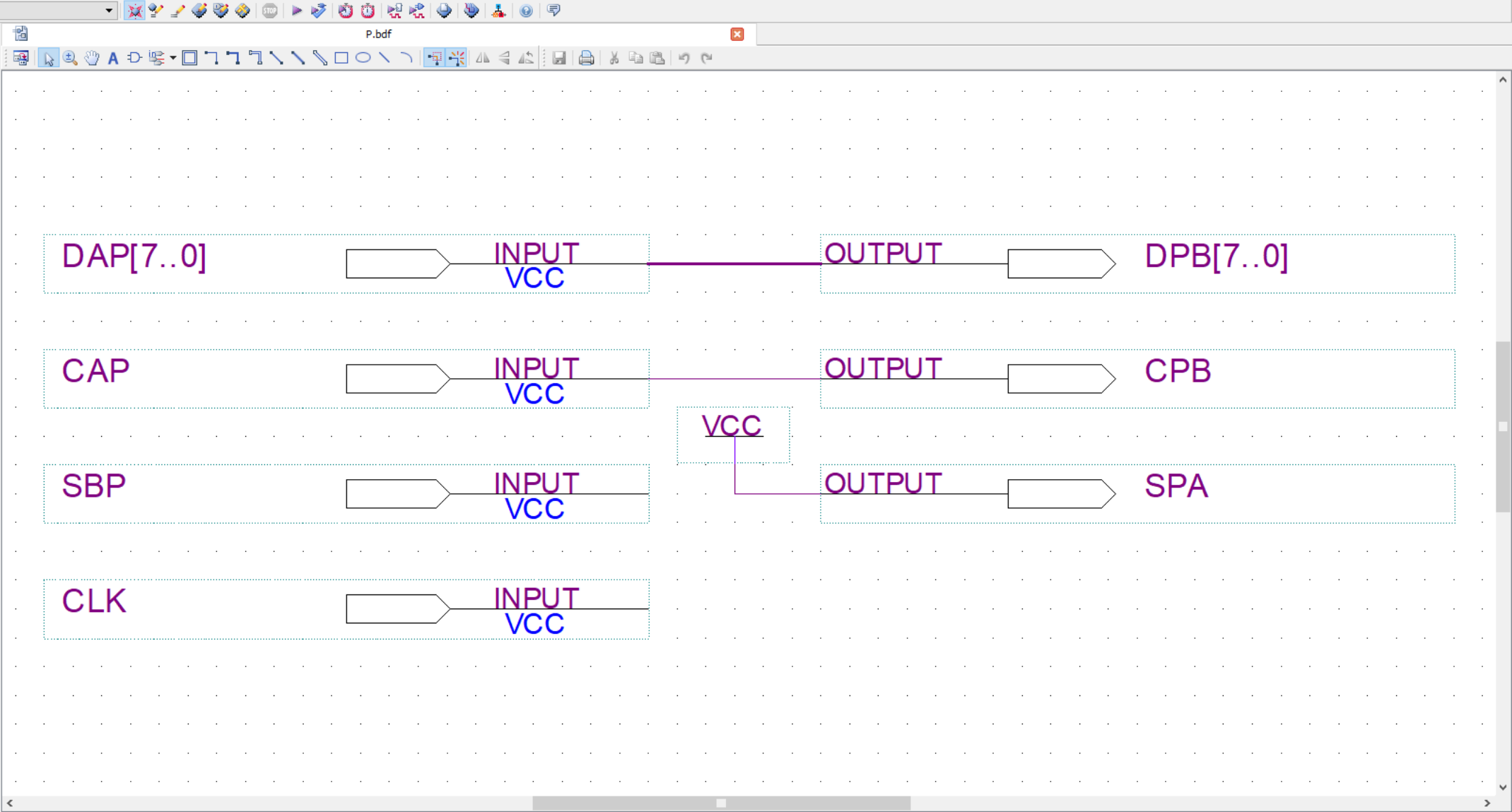

Hierarchy

Files

Design Units

Tasks

Flow: Compilation

Customize...

Task	
?	Compile Design
?	> Analysis & Synthesis
?	> Fitter (Place & Route)
?	> Assembler (Generate programming files)
?	> TimeQuest Timing Analysis
?	> EDA Netlist Writer
	Program Device (Open Programmer)

Messages

All

<<Search>>

Type	ID	Message

System Processing

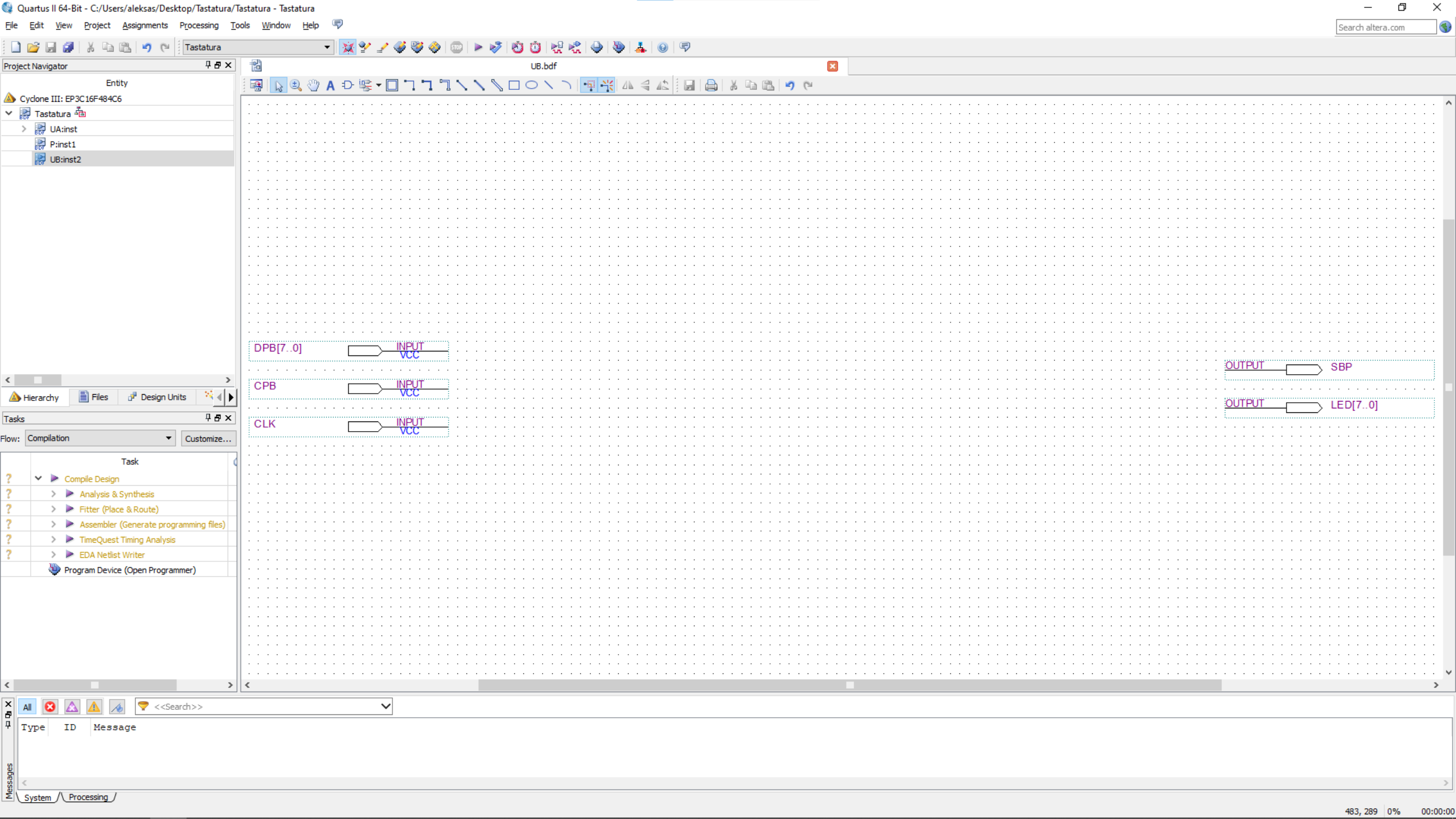



Project Navigator

Entity

- Cyclone III: EP3C16F484C6
  - Tastatura
    - UA:inst
    - P:inst1
    - UB:inst2

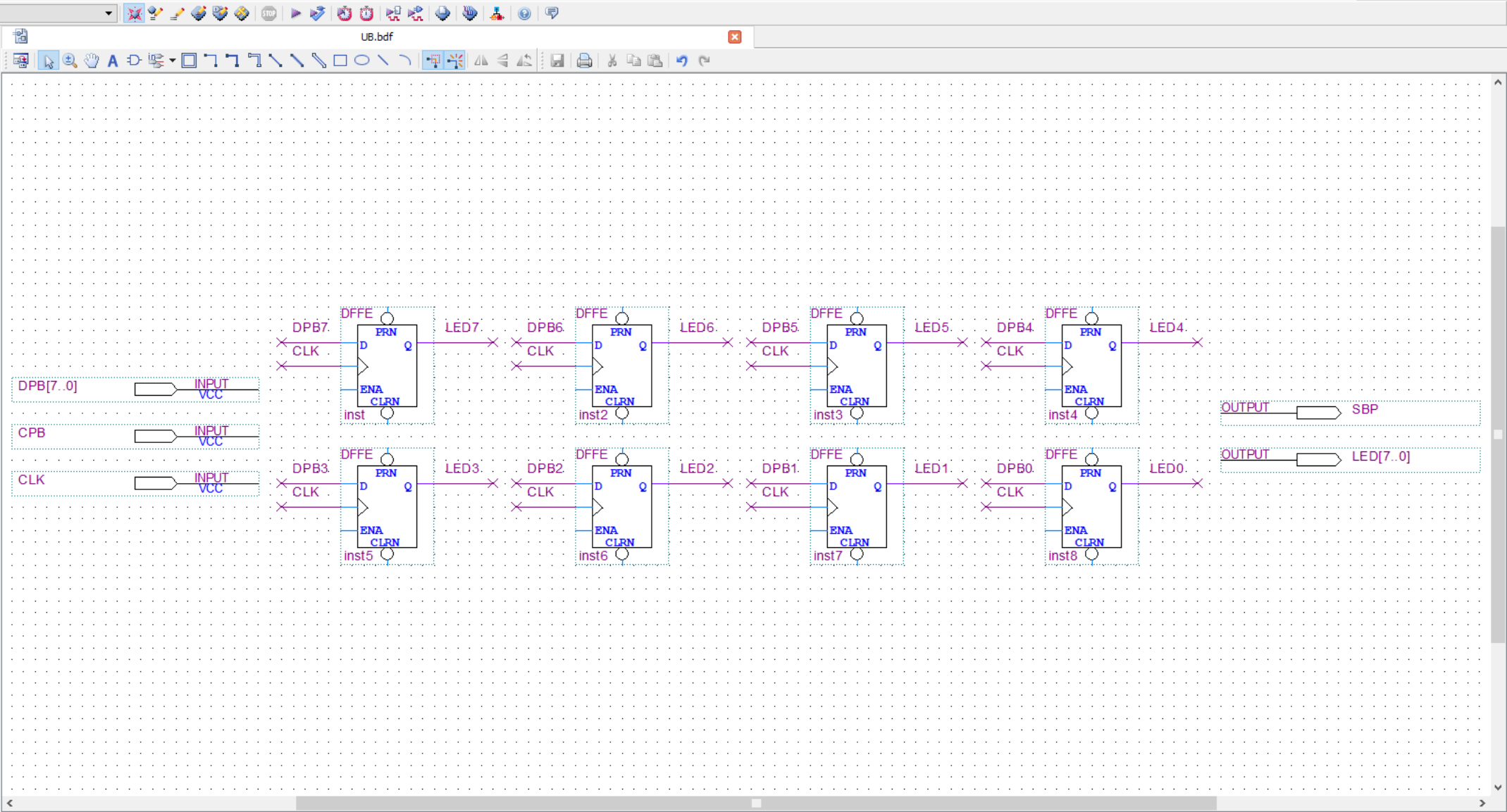

Hierarchy

Files

Design Units

Tasks

Flow: Compilation

Customize...

- Task
- Compile Design
- Analysis & Synthesis
- Fitter (Place & Route)
- Assembler (Generate programming files)
- TimeQuest Timing Analysis
- EDA Netlist Writer
- Program Device (Open Programmer)

All

<<Search>>

Type	ID	Message
System		Processing

Project Navigator

Entity

- Cyclone III: EP3C16F484C6
  - Tastatura
    - UA:inst
    - P:inst1
    - UB:inst2

UB.bdf

Hierarchy

Files

Design Units

Tasks

Flow: Compilation

- Compile Design
  - Analysis & Synthesis
  - Fitter (Place & Route)
  - Assembler (Generate programming files)
  - TimeQuest Timing Analysis
  - EDA Netlist Writer
- Program Device (Open Programmer)

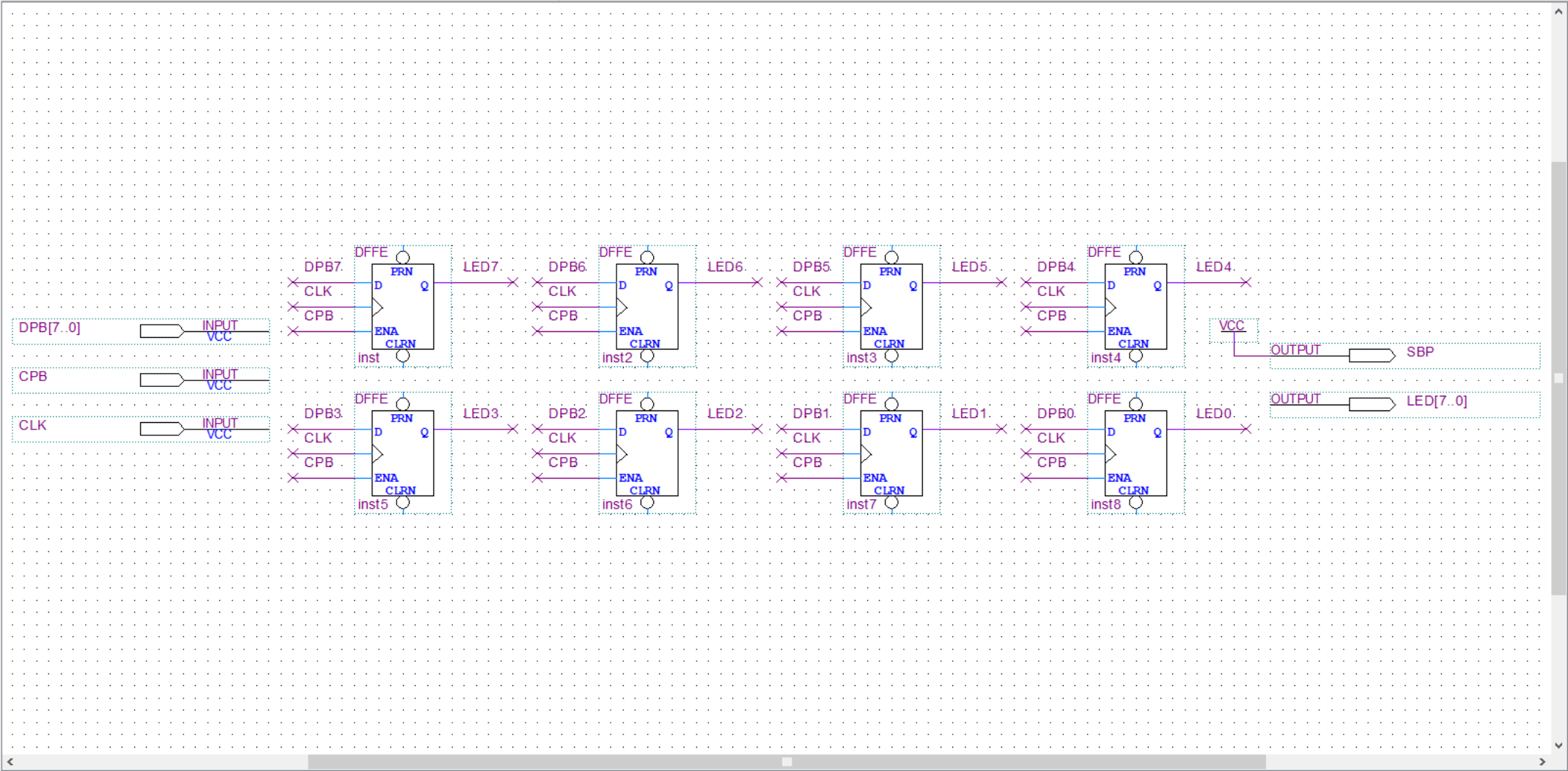

Messages

All

<<Search>>

Type	ID	Message
System		Processing

Project Navigator

Entity

- Cyclone III: EP3C16F484C6
  - Tastatura
    - UA:inst
    - P:inst1
    - UB:inst2

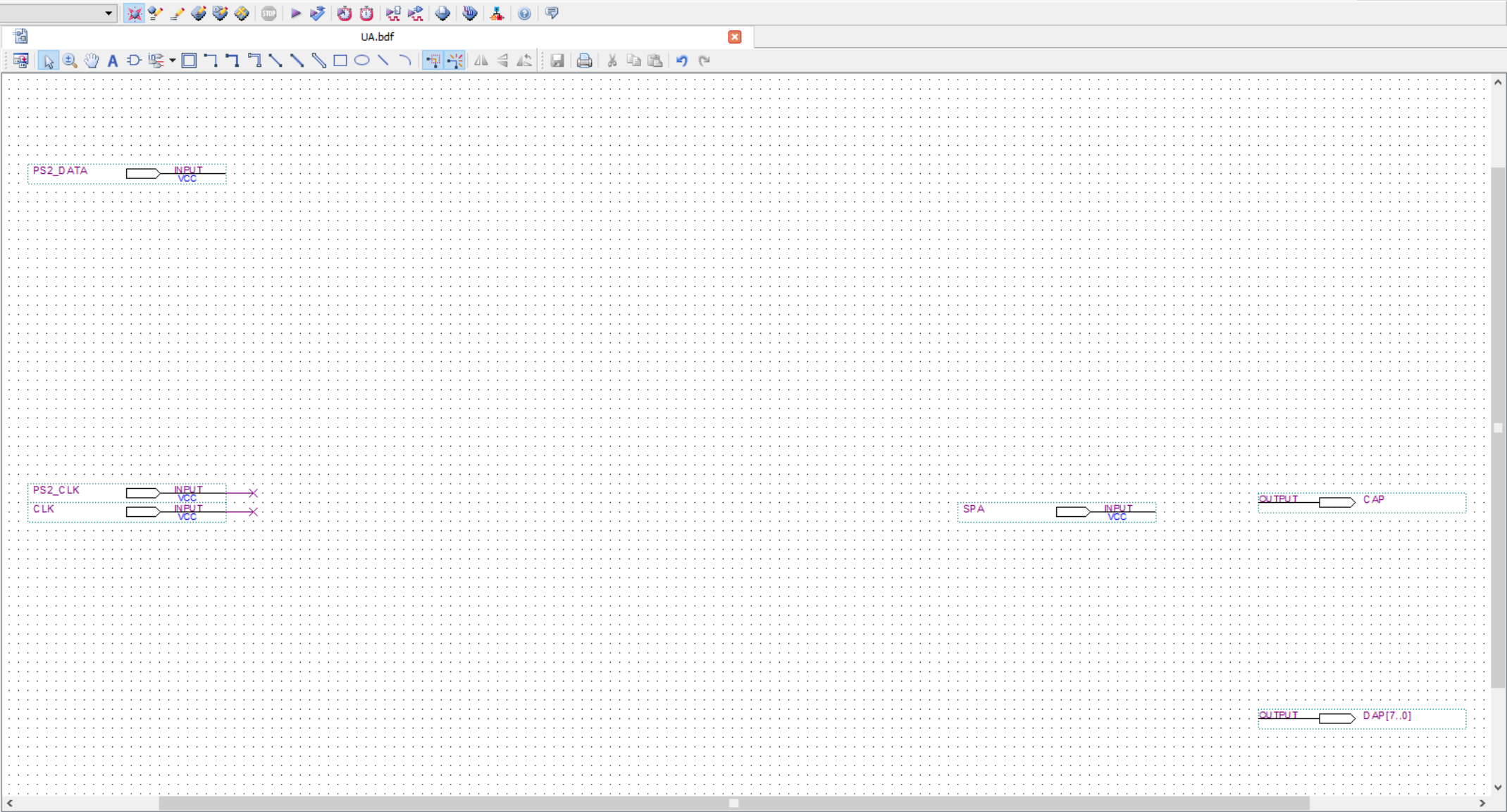

Hierarchy | Files | Design Units

Tasks

Flow: **Compilation** | Customize...

- Task
- Compile Design
  - Analysis & Synthesis
  - Fitter (Place & Route)
  - Assembler (Generate programming files)
  - TimeQuest Timing Analysis
  - EDA Netlist Writer
- Program Device (Open Programmer)

All | <<Search>>

Type	ID	Message
System		Processing

Project Navigator

Entity

- Cyclone III: EP3C16F484C6
  - Tastatura
    - UA:inst
    - P:inst1
    - UB:inst2

UA.bdf

Hierarchy

Files

Design Units

Tasks

Flow: Compilation

Customize...

Task
Compile Design
Analysis & Synthesis
Fitter (Place & Route)
Assembler (Generate programming files)
TimeQuest Timing Analysis
EDA Netlist Writer
Program Device (Open Programmer)

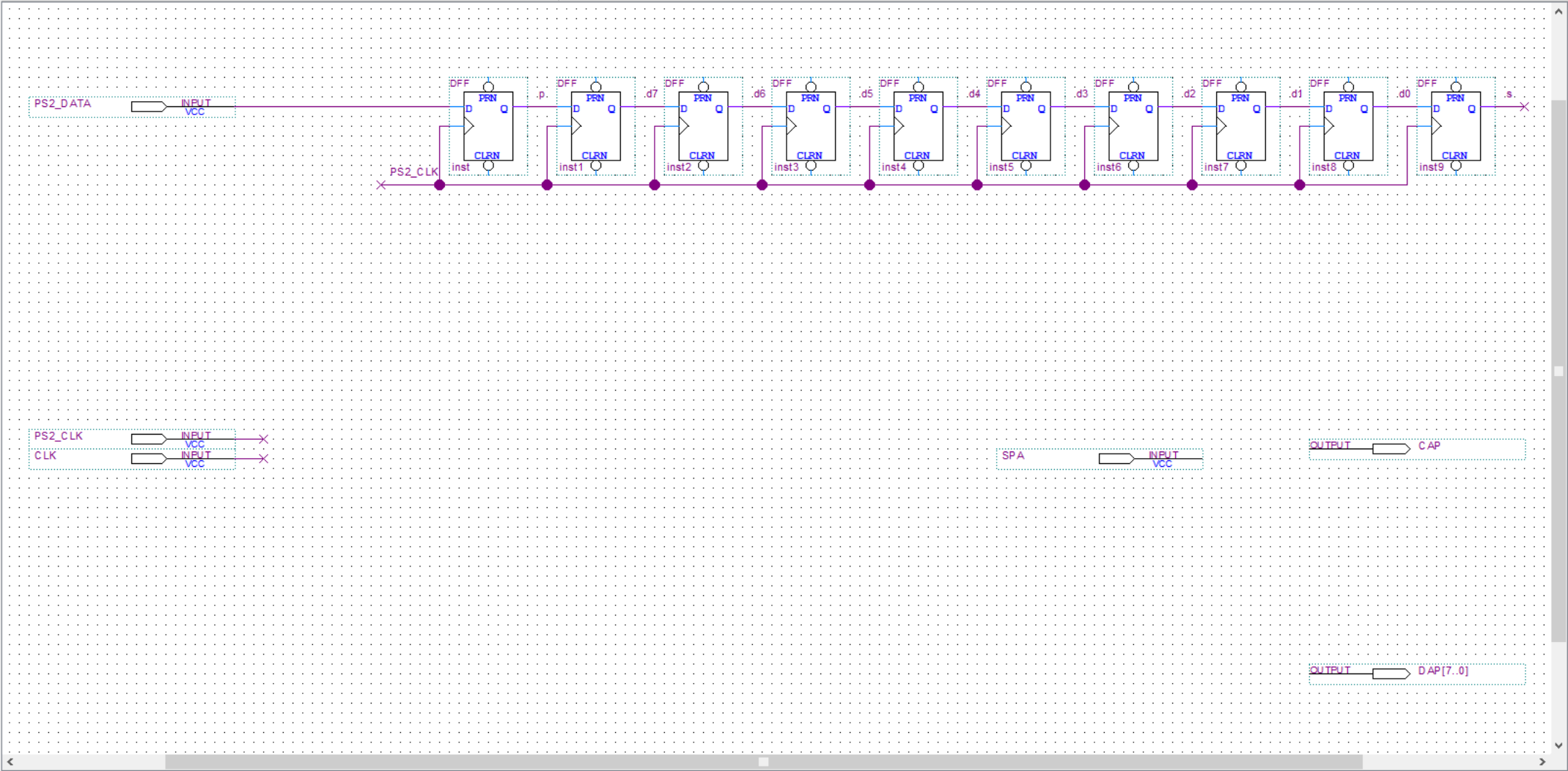

Messages

Type	ID	Message
System		Processing

Project Navigator

Entity

- Cydone III: EP3C16F484C6
  - Tastatura
    - UA:inst
    - P:inst1
    - UB:inst2

UA.bdf

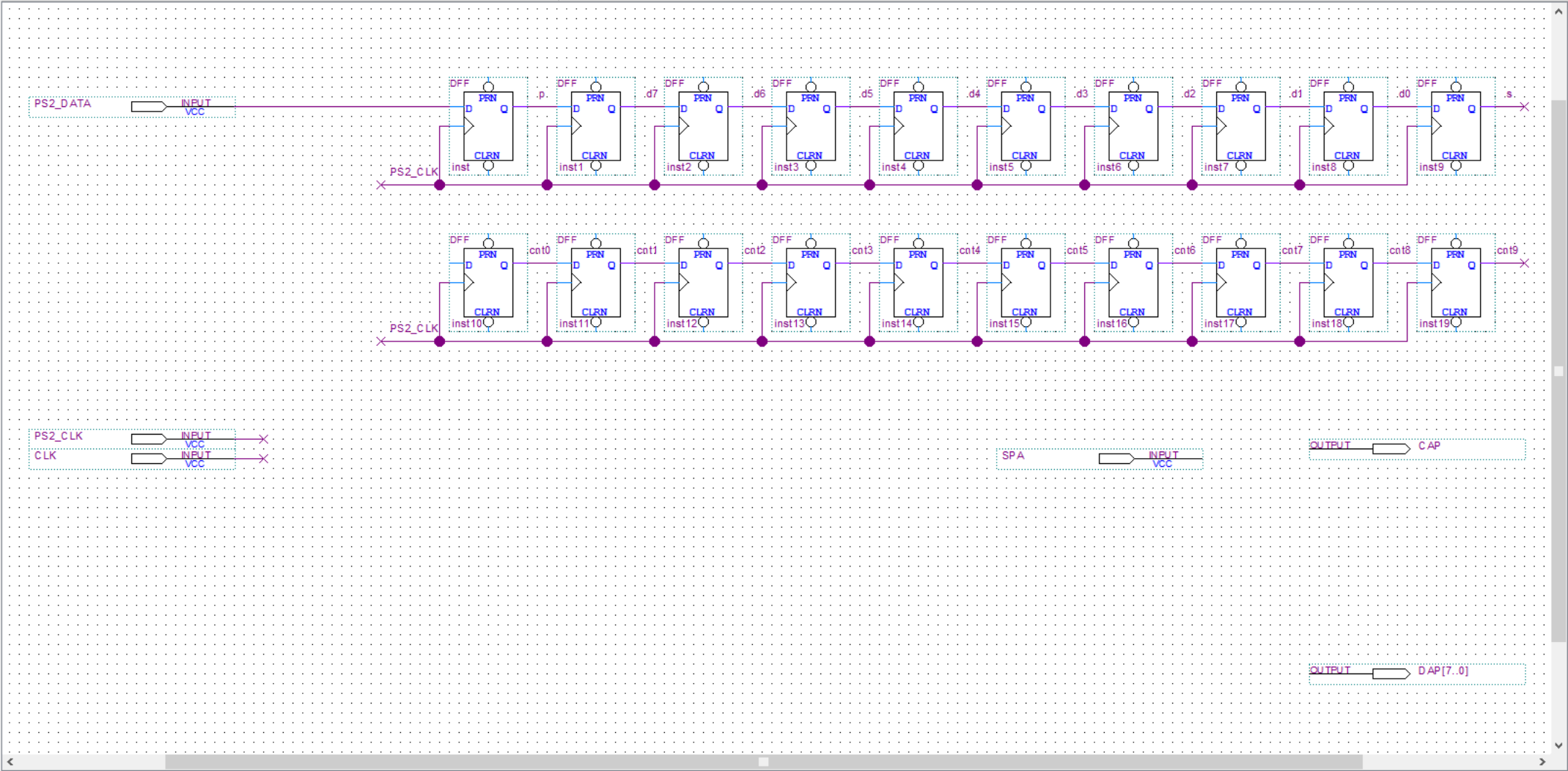

Hierarchy

Files

Design Units

Tasks

Flow: Compilation

Customize...

- Task
- Compile Design
- Analysis & Synthesis
- Fitter (Place & Route)
- Assembler (Generate programming files)
- TimeQuest Timing Analysis
- EDA Netlist Writer
- Program Device (Open Programmer)

All

<<Search>>

Type	ID	Message
System		Processing

Project Navigator

Entity

- Cydone III: EP3C16F484C6
  - Tastatura
    - UA:inst
    - P:inst1
    - UB:inst2

UA.bdf

Hierarchy

Files

Design Units

Tasks

Flow: Compilation

Customize...

Task
Compile Design
Analysis & Synthesis
Fitter (Place & Route)
Assembler (Generate programming files)
TimeQuest Timing Analysis
EDA Netlist Writer
Program Device (Open Programmer)

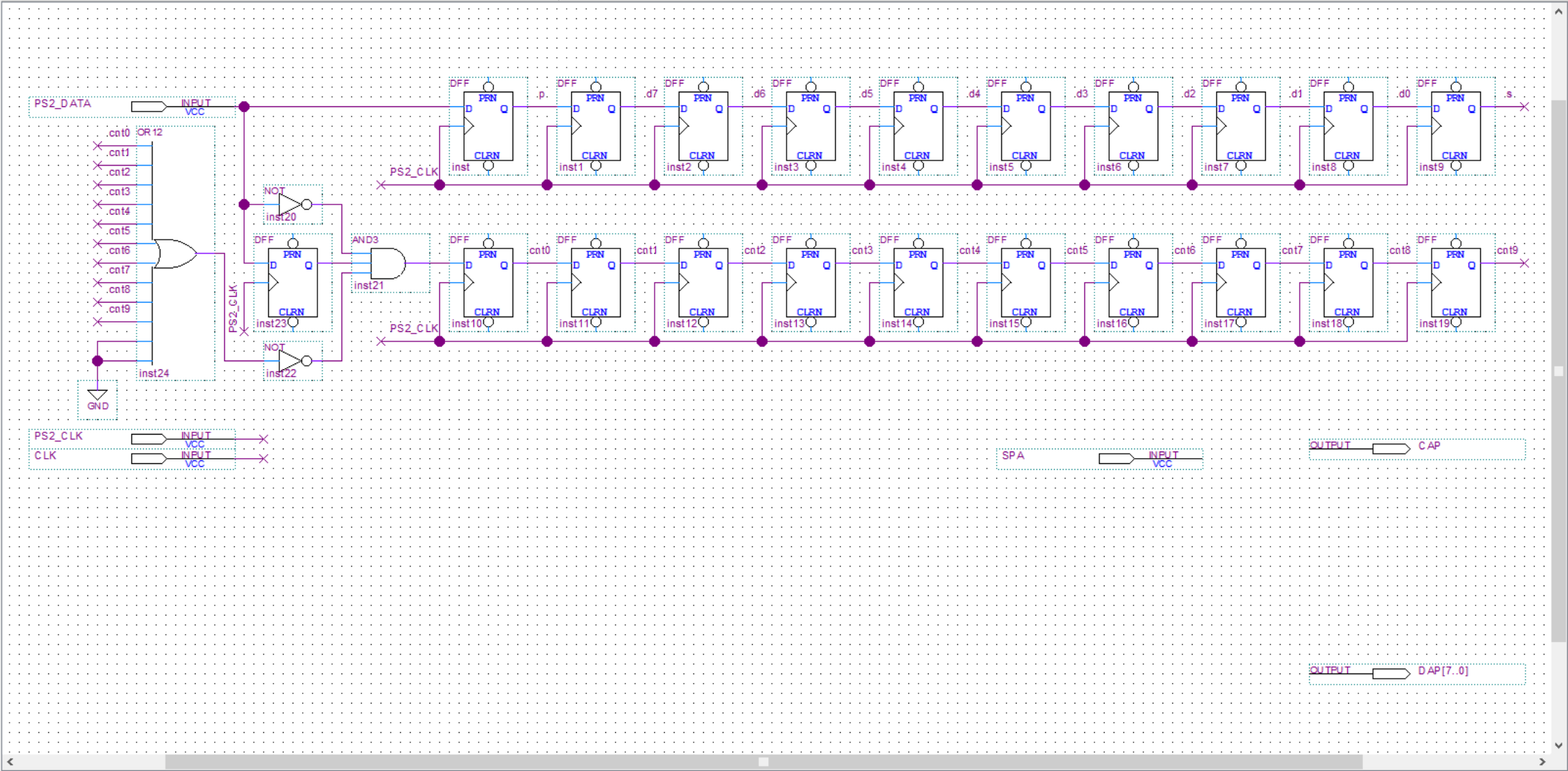

All

<<Search>>

Type	ID	Message
System		Processing

Project Navigator

Entity

- Cyclone III: EP3C16F484C6
  - Tastatura
    - UA:inst
    - P:inst1
    - UB:inst2

UA.bdf

Hierarchy Files Design Units

Tasks

Flow: Compilation Customize...

Task
Compile Design
Analysis & Synthesis
Fitter (Place & Route)
Assembler (Generate programming files)
TimeQuest Timing Analysis
EDA Netlist Writer
Program Device (Open Programmer)

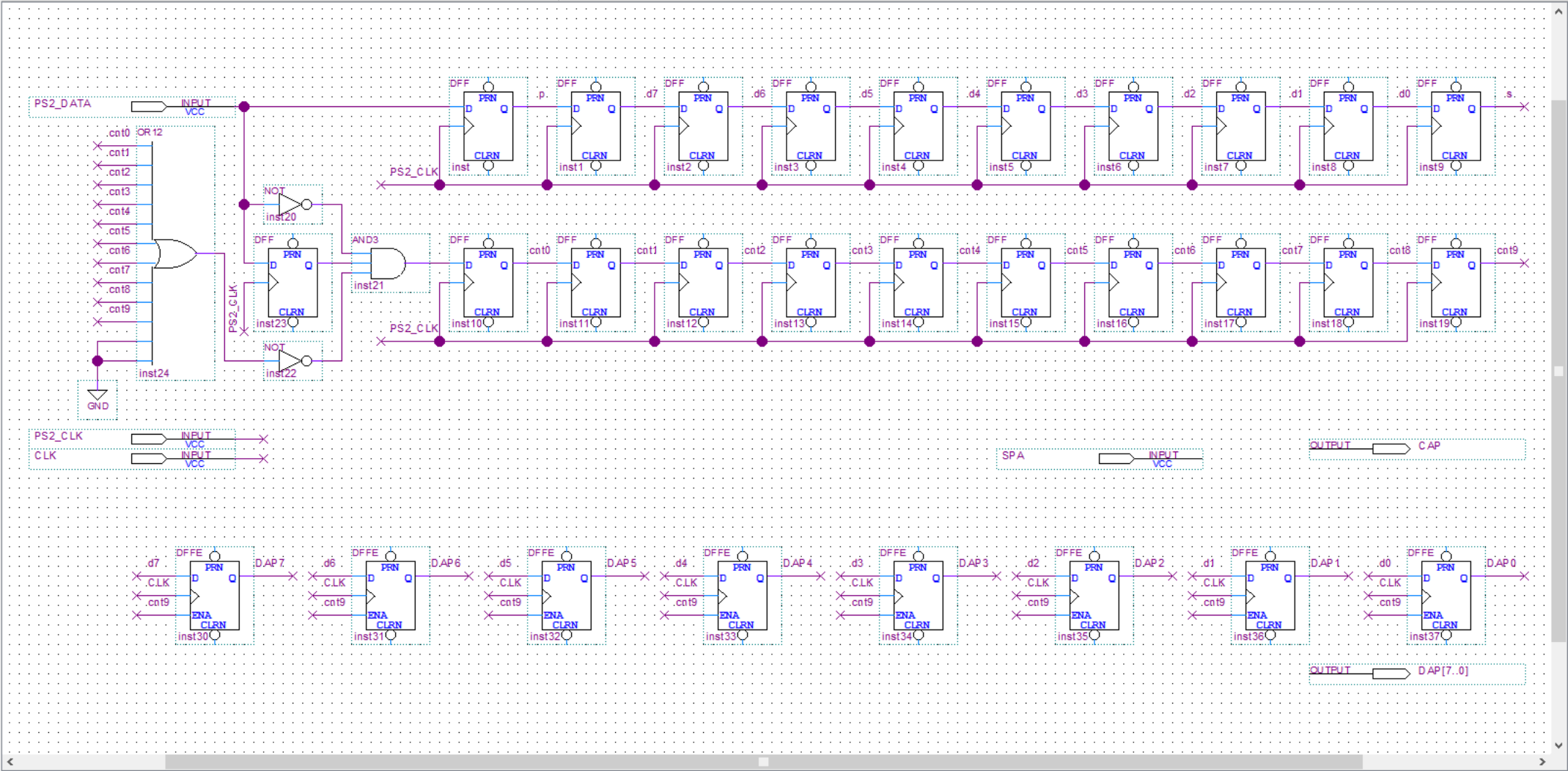

Messages

Type	ID	Message
System		Processing

Project Navigator

Entity

- Cyclone III: EP3C16F484C6
  - Tastatura
    - UA:inst
    - P:inst1
    - UB:inst2

Hierarchy

Files

Design Units

Tasks

Flow: Compilation

Customize...

Task
Compile Design
Analysis & Synthesis
Fitter (Place & Route)
Assembler (Generate programming files)
TimeQuest Timing Analysis
EDA Netlist Writer
Program Device (Open Programmer)

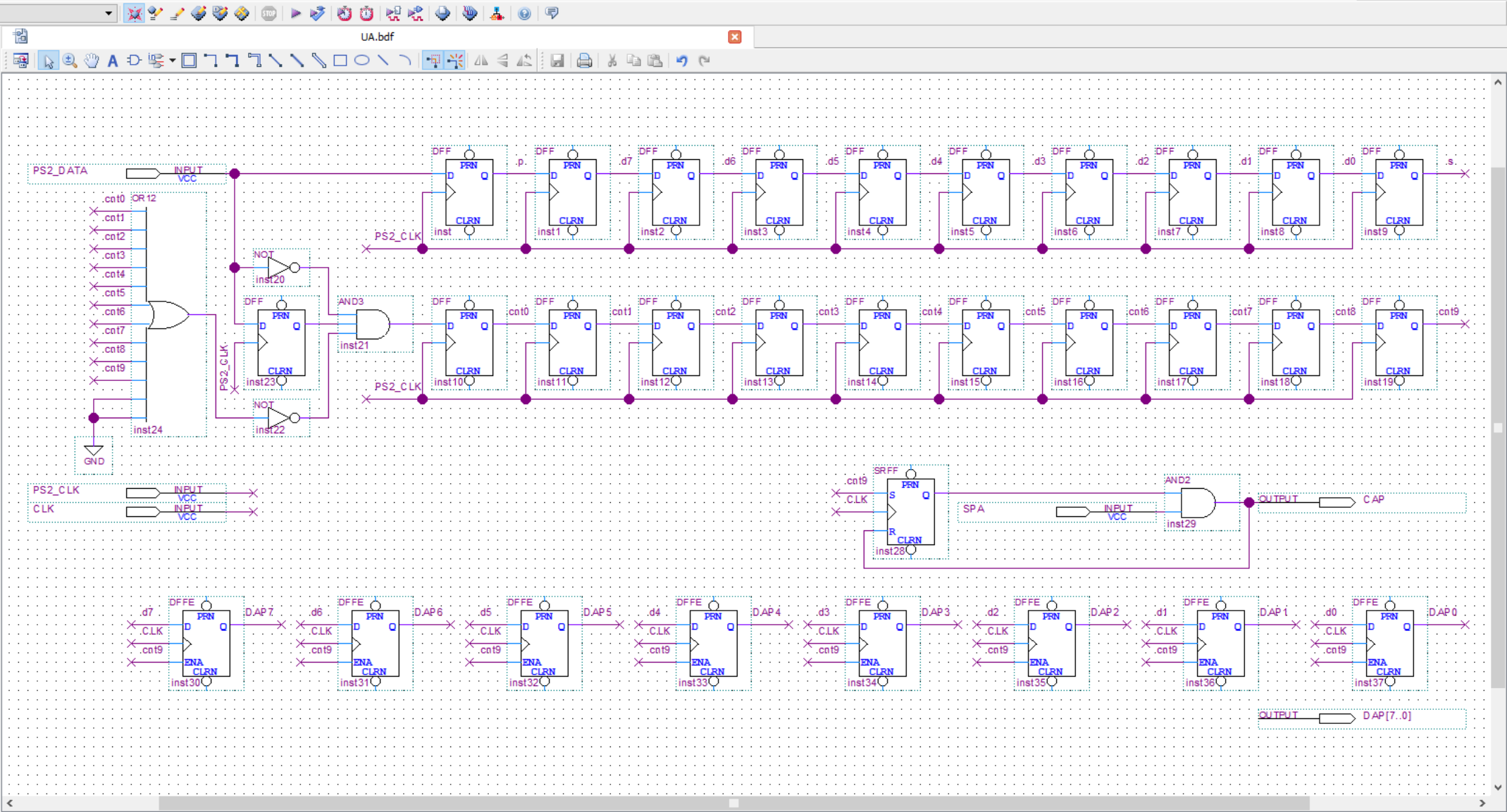

Messages

Type	ID	Message
System		Processing



Project Navigator

Entity

- Cydone III: EP3C16F484C6
  - Tastatura
    - UA:inst
      - RisingEdgeDetector:inst38
      - Debouncer:inst39
      - P:inst1
      - UB:inst2

Hierarchy Files Design Units

Tasks

Flow: Compilation Customize...

Task
Compile Design
Analysis & Synthesis
Fitter (Place & Route)
Assembler (Generate programming files)
TimeQuest Timing Analysis
EDA Netlist Writer
Program Device (Open Programmer)

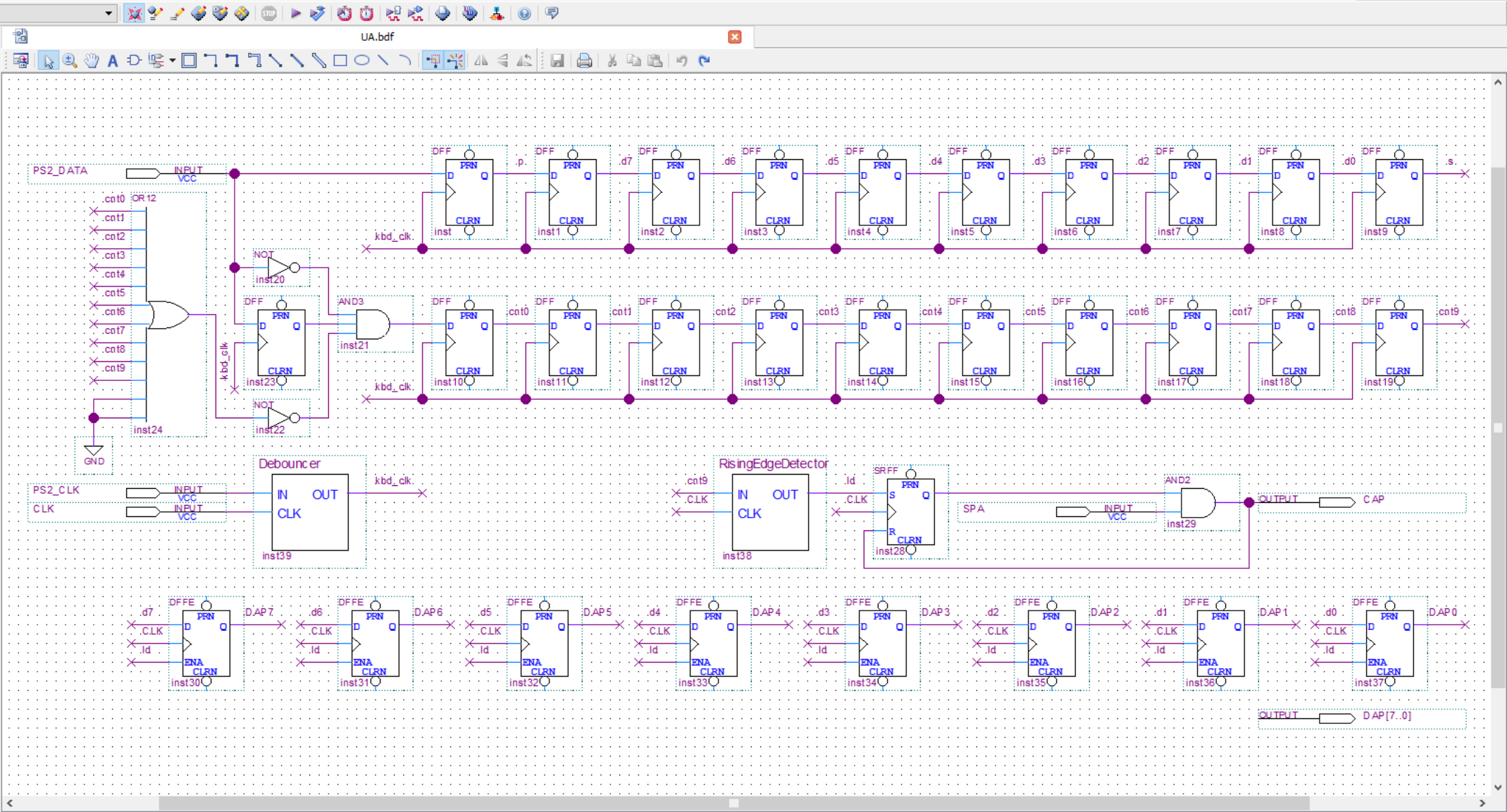

Messages

Type	ID	Message
System		Processing

296, 98 0% 00:00:00

Project Navigator

Entity

- Cyclone III: EP3C16F484C6
  - Tastatura
    - UA:inst
      - RisingEdgeDetector:inst38
      - Debouncer:inst39
    - P:inst1
    - UB:inst2

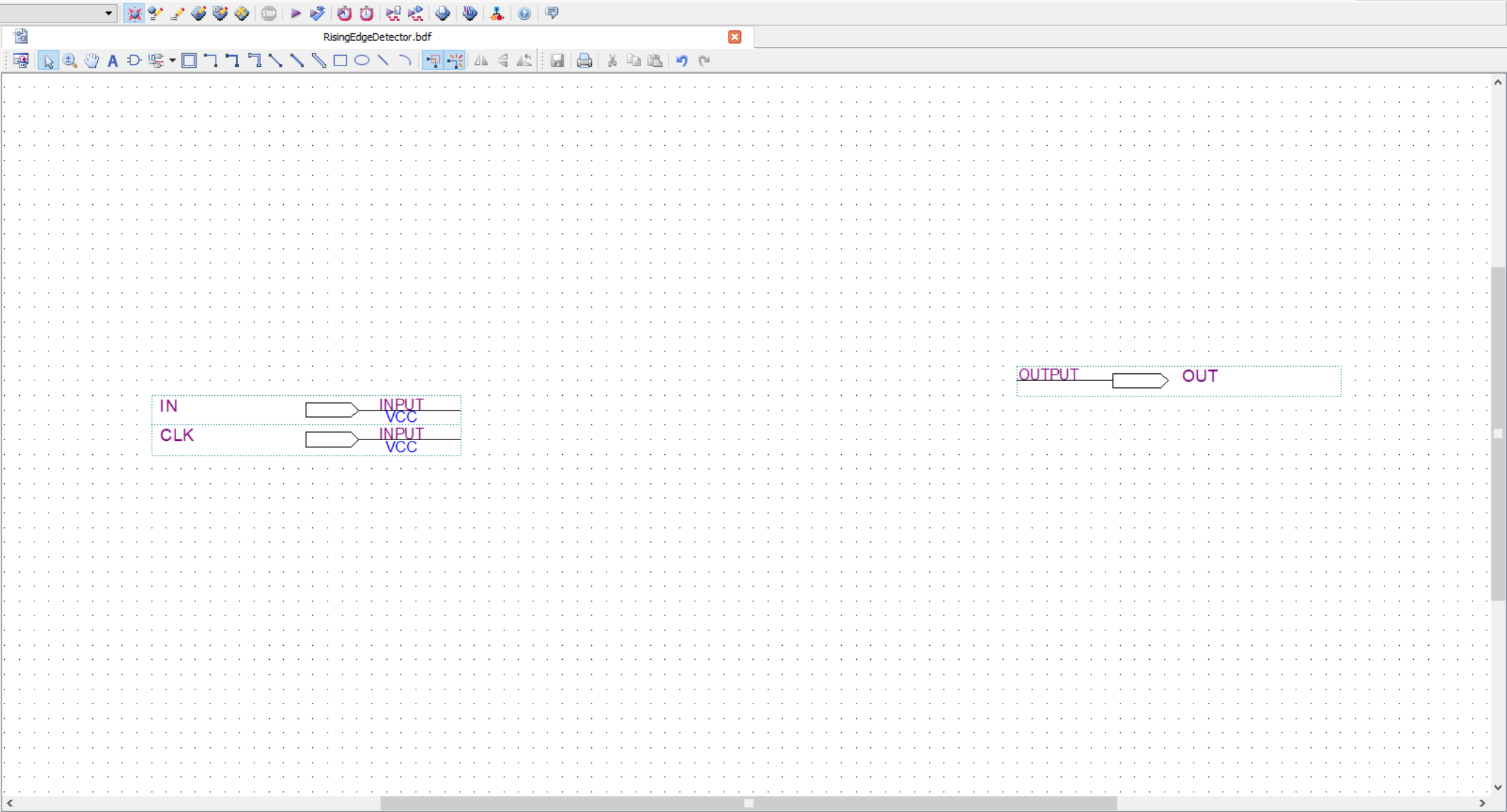

Hierarchy Files Design Units

Tasks

Flow: Compilation Customize...

- Task
  - Compile Design
    - Analysis & Synthesis
    - Fitter (Place & Route)
    - Assembler (Generate programming files)
    - TimeQuest Timing Analysis
    - EDA Netlist Writer
  - Program Device (Open Programmer)

All [Icons] <<Search>>

Type	ID	Message
Messages		
System Processing		

Project Navigator

Entity

- Cyclone III: EP3C16F484C6
  - Tastatura
    - UA:inst
      - RisingEdgeDetector:inst38
      - Debouncer:inst39
    - P:inst1
    - UB:inst2

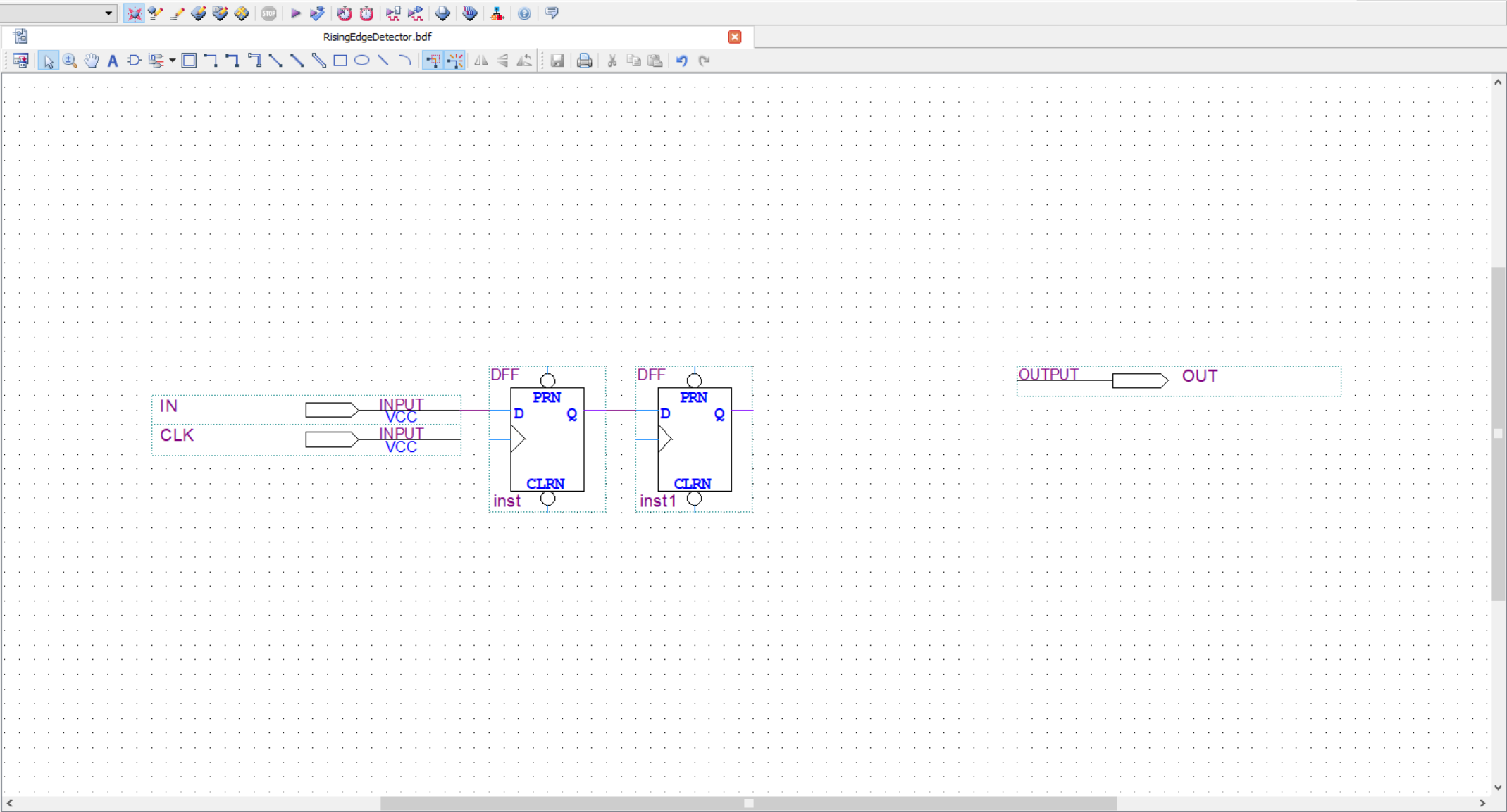

Hierarchy Files Design Units

Tasks

Flow: Compilation Customize...

- Task
  - Compile Design
    - Analysis & Synthesis
    - Fitter (Place & Route)
    - Assembler (Generate programming files)
    - TimeQuest Timing Analysis
    - EDA Netlist Writer
  - Program Device (Open Programmer)

All <<Search>>

Type	ID	Message
System		Processing

Project Navigator

Entity

- Cyclone III: EP3C16F484C6
  - Tastatura
    - UA:inst
      - RisingEdgeDetector:inst38
      - Debounce:inst39
      - P:inst1
      - UB:inst2

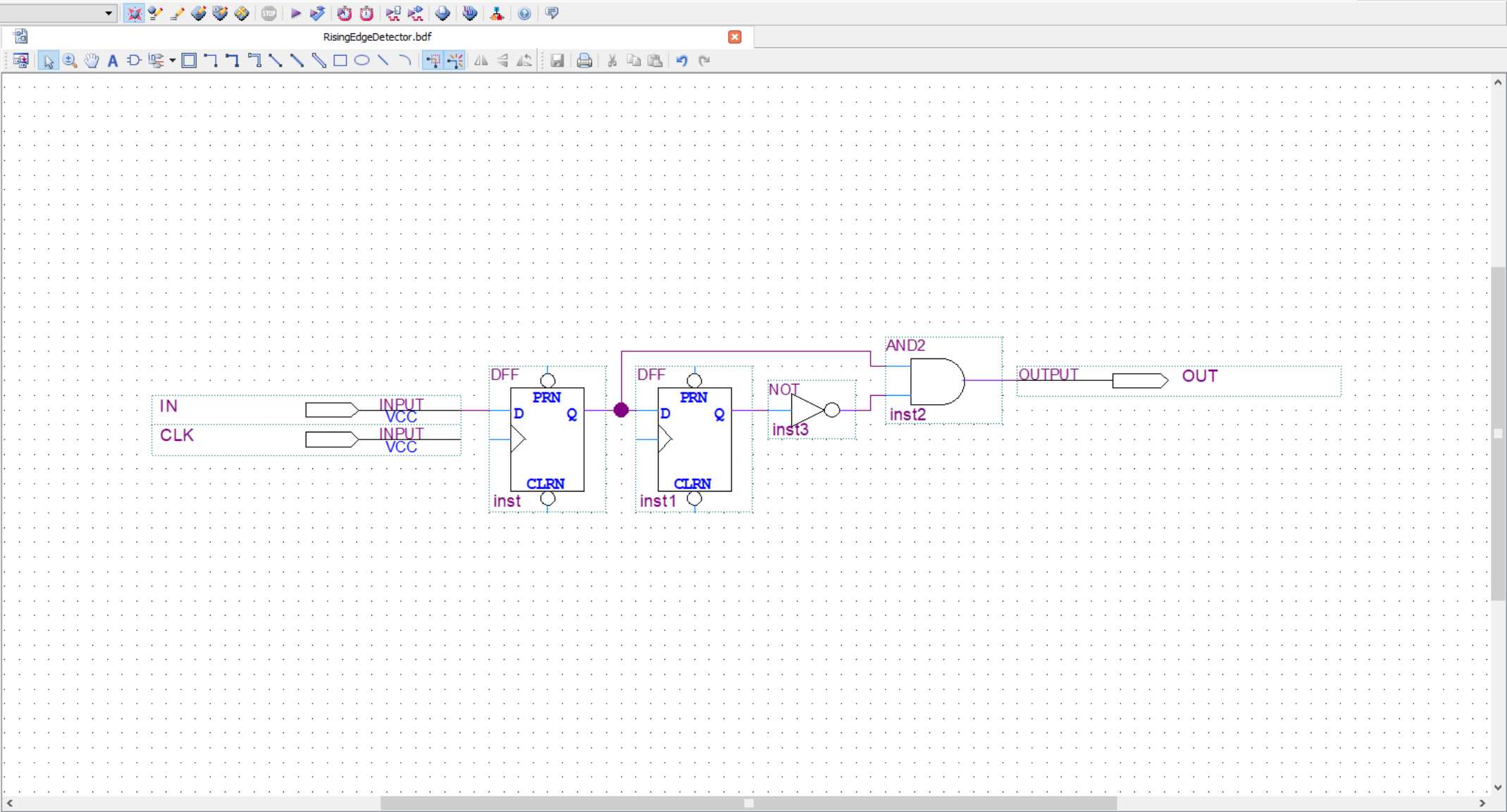

Hierarchy Files Design Units

Tasks

Flow: Compilation Customize...

- Task
- Compile Design
  - Analysis & Synthesis
  - Fitter (Place & Route)
  - Assembler (Generate programming files)
  - TimeQuest Timing Analysis
  - EDA Netlist Writer
- Program Device (Open Programmer)

All <<Search>>

Type	ID	Message

Project Navigator

Entity

- Cyclone III: EP3C16F484C6
  - Tastatura
    - UA:inst
      - RisingEdgeDetector:inst38
      - Debounce:inst39
      - P:inst1
      - UB:inst2

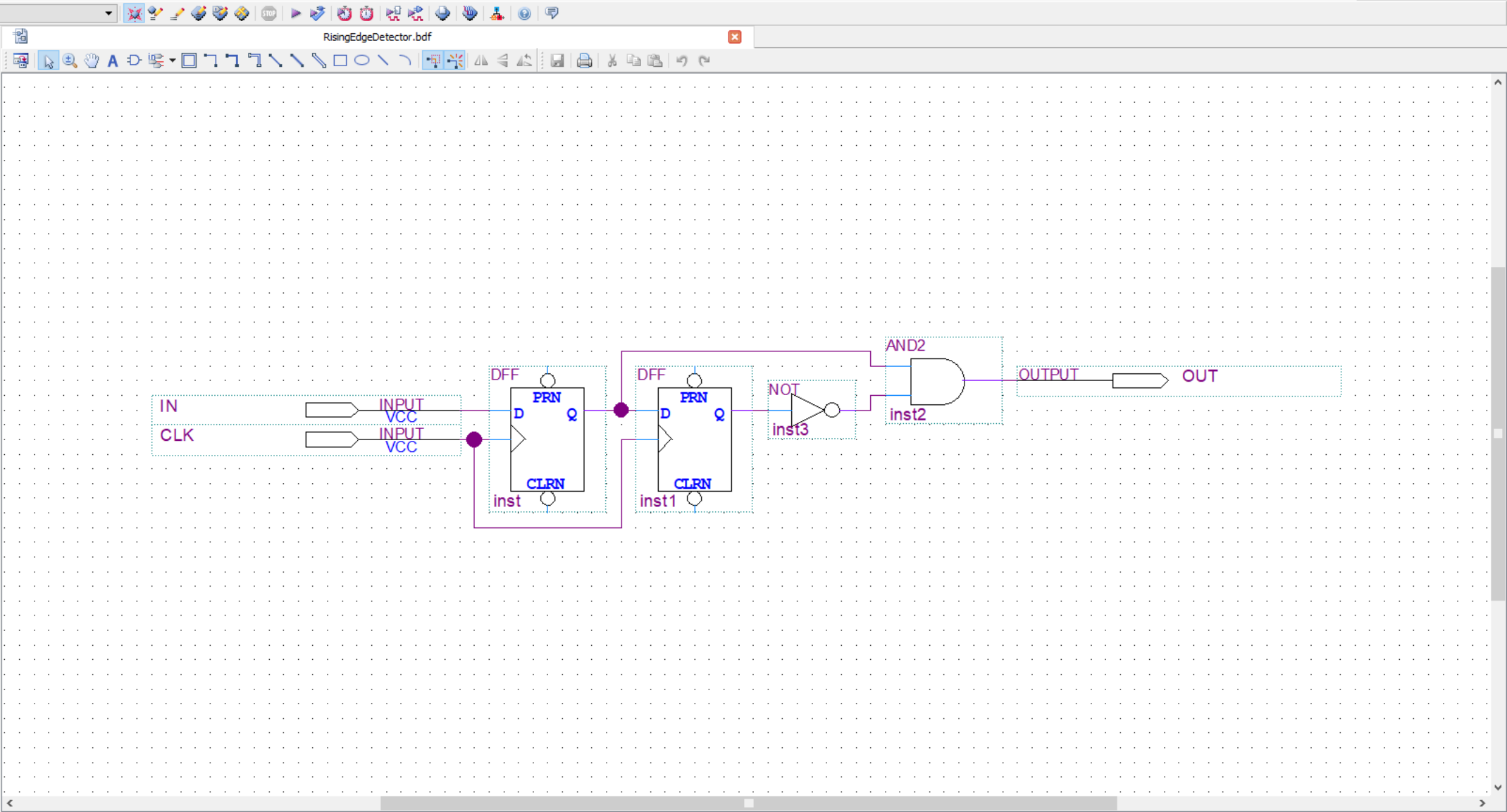

Hierarchy Files Design Units

Tasks

Flow: Compilation Customize...

- Task
  - Compile Design
    - Analysis & Synthesis
    - Fitter (Place & Route)
    - Assembler (Generate programming files)
    - TimeQuest Timing Analysis
    - EDA Netlist Writer
  - Program Device (Open Programmer)

All <<Search>>

Type	ID	Message
------	----	---------

Project Navigator

Entity

- Cyclone III: EP3C16F484C6
  - Tastatura
    - UA:inst
      - RisingEdgeDetector:inst38
      - Debounce:inst39
    - P:inst1
    - UB:inst2

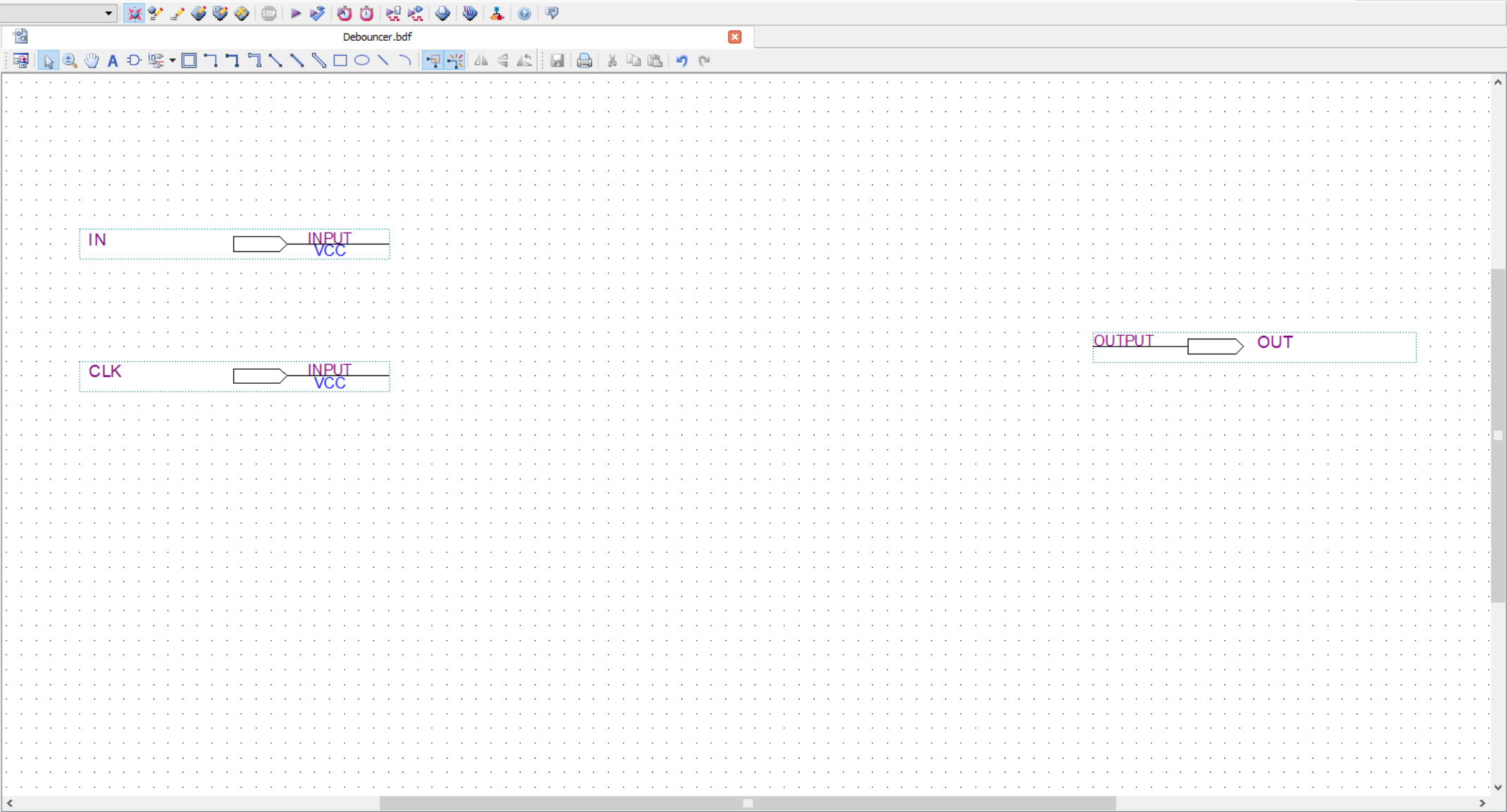

Hierarchy Files Design Units

Tasks

Flow: Compilation Customize...

- Task
  - Compile Design
    - Analysis & Synthesis
    - Fitter (Place & Route)
    - Assembler (Generate programming files)
    - TimeQuest Timing Analysis
    - EDA Netlist Writer
  - Program Device (Open Programmer)

All [Icons] <<Search>>

Type	ID	Message

Project Navigator

Entity

- Cyclone III: EP3C16F484C6
  - Tastatura
    - UA:inst
      - RisingEdgeDetector:inst38
      - Debounce:inst39
      - P:inst1
      - UB:inst2

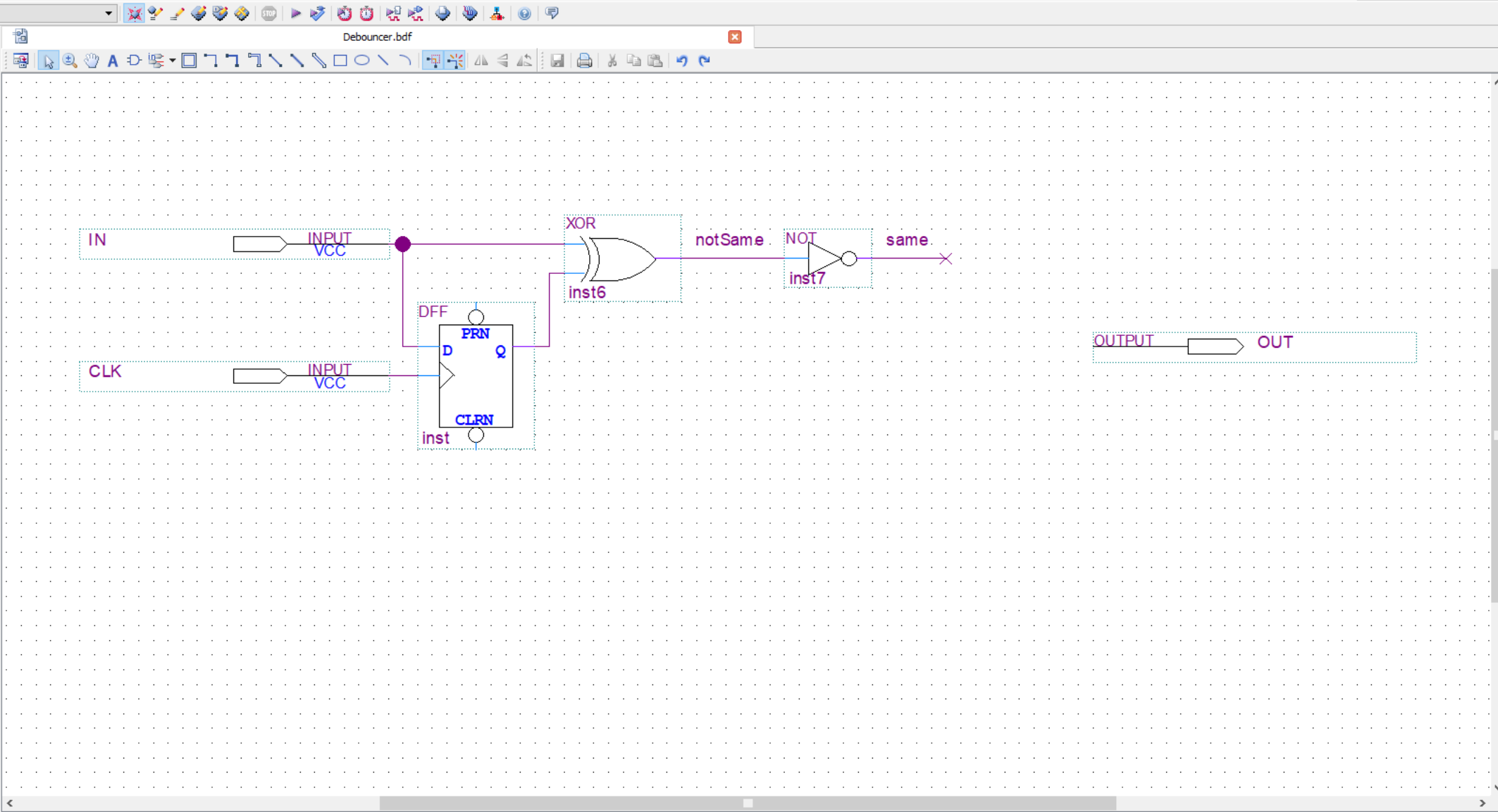

Hierarchy Files Design Units

Tasks

Flow: Compilation Customize...

Task	
?	Compile Design
?	> Analysis & Synthesis
?	> Fitter (Place & Route)
?	> Assembler (Generate programming files)
?	> TimeQuest Timing Analysis
?	> EDA Netlist Writer
	Program Device (Open Programmer)

Messages

All <<Search>>

Type	ID	Message
------	----	---------

System Processing

Project Navigator

Entity

- Cyclone III: EP3C16F484C6
  - Tastatura
    - UA:inst
      - RisingEdgeDetector:inst38
      - Debounce:inst39
    - P:inst1
    - UB:inst2

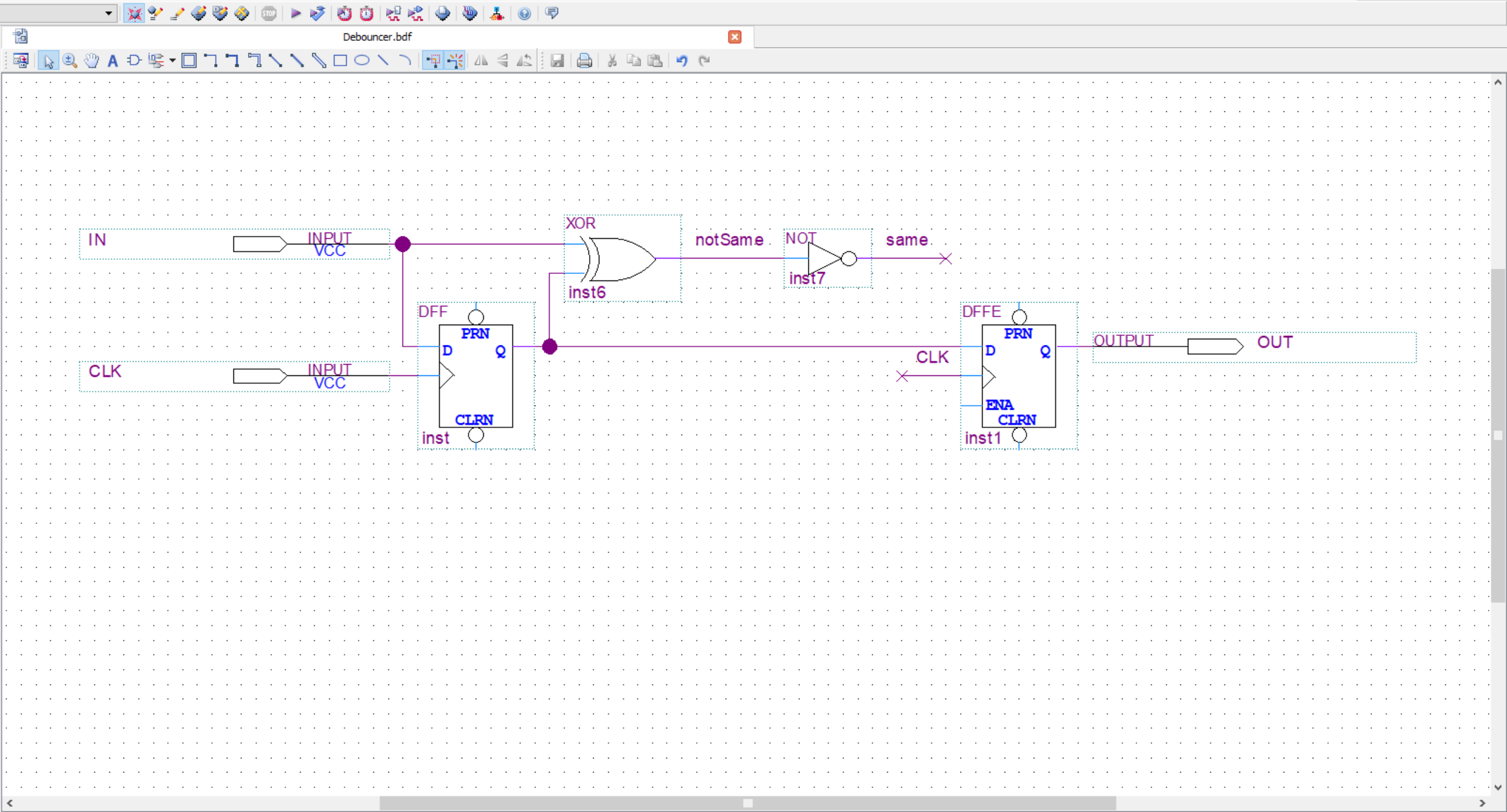

Hierarchy Files Design Units

Tasks

Flow: Compilation Customize...

- Task
  - Compile Design
    - Analysis & Synthesis
    - Fitter (Place & Route)
    - Assembler (Generate programming files)
    - TimeQuest Timing Analysis
    - EDA Netlist Writer
  - Program Device (Open Programmer)

All <<Search>>

Type	ID	Message
System	Processing	



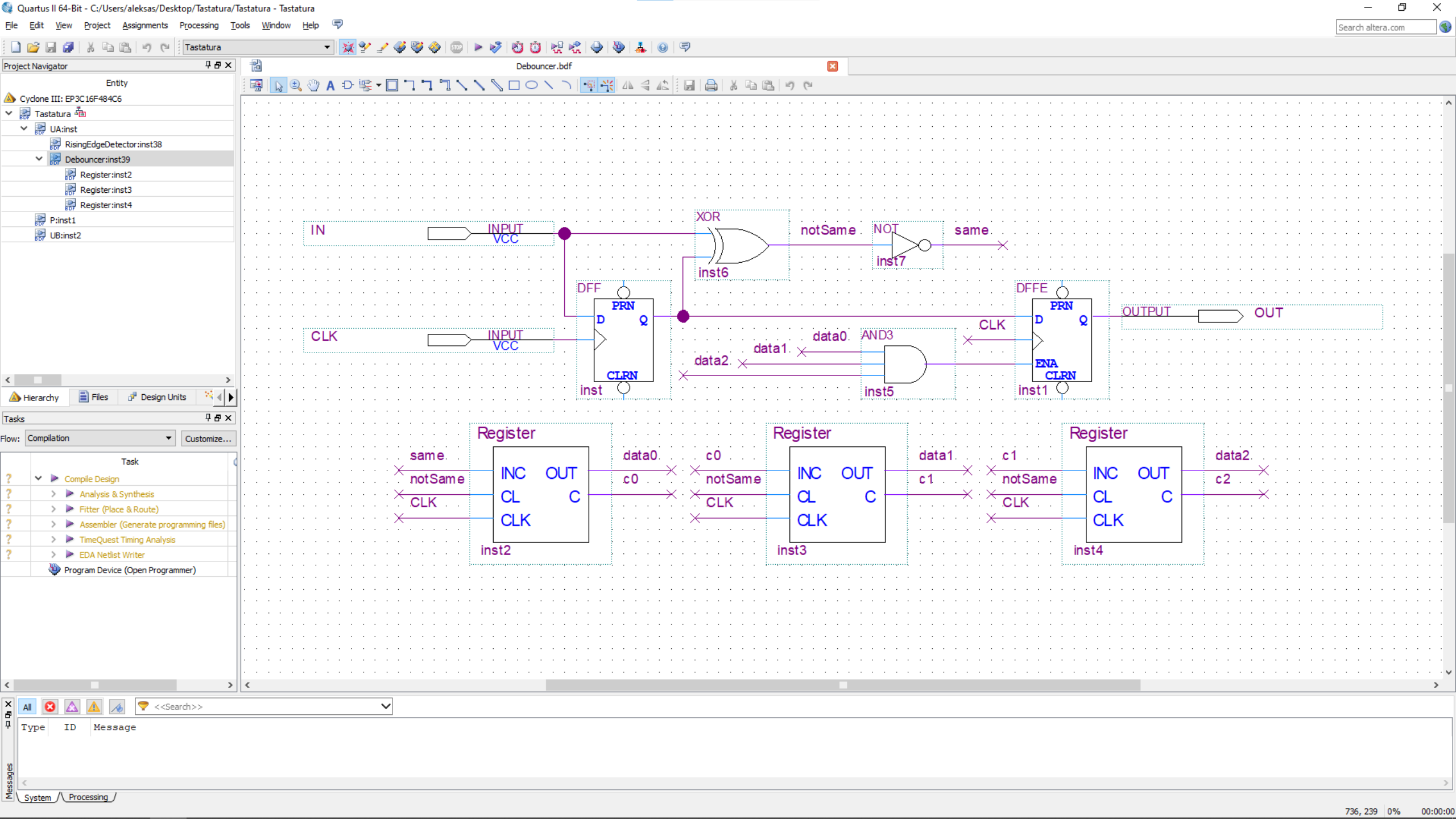

Project Navigator

Entity

- Cyclone III: EP3C16F484C6
  - Tastatura
    - UA:inst
      - RisingEdgeDetector:inst38
        - Debouncer:inst39
          - Register:inst2
          - Register:inst3
          - Register:inst4
        - P:inst1
        - UB:inst2

Tasks

Flow: Compilation

- Compile Design
  - Analysis & Synthesis
  - Fitter (Place & Route)
  - Assembler (Generate programming files)
  - TimeQuest Timing Analysis
  - EDA Netlist Writer
- Program Device (Open Programmer)

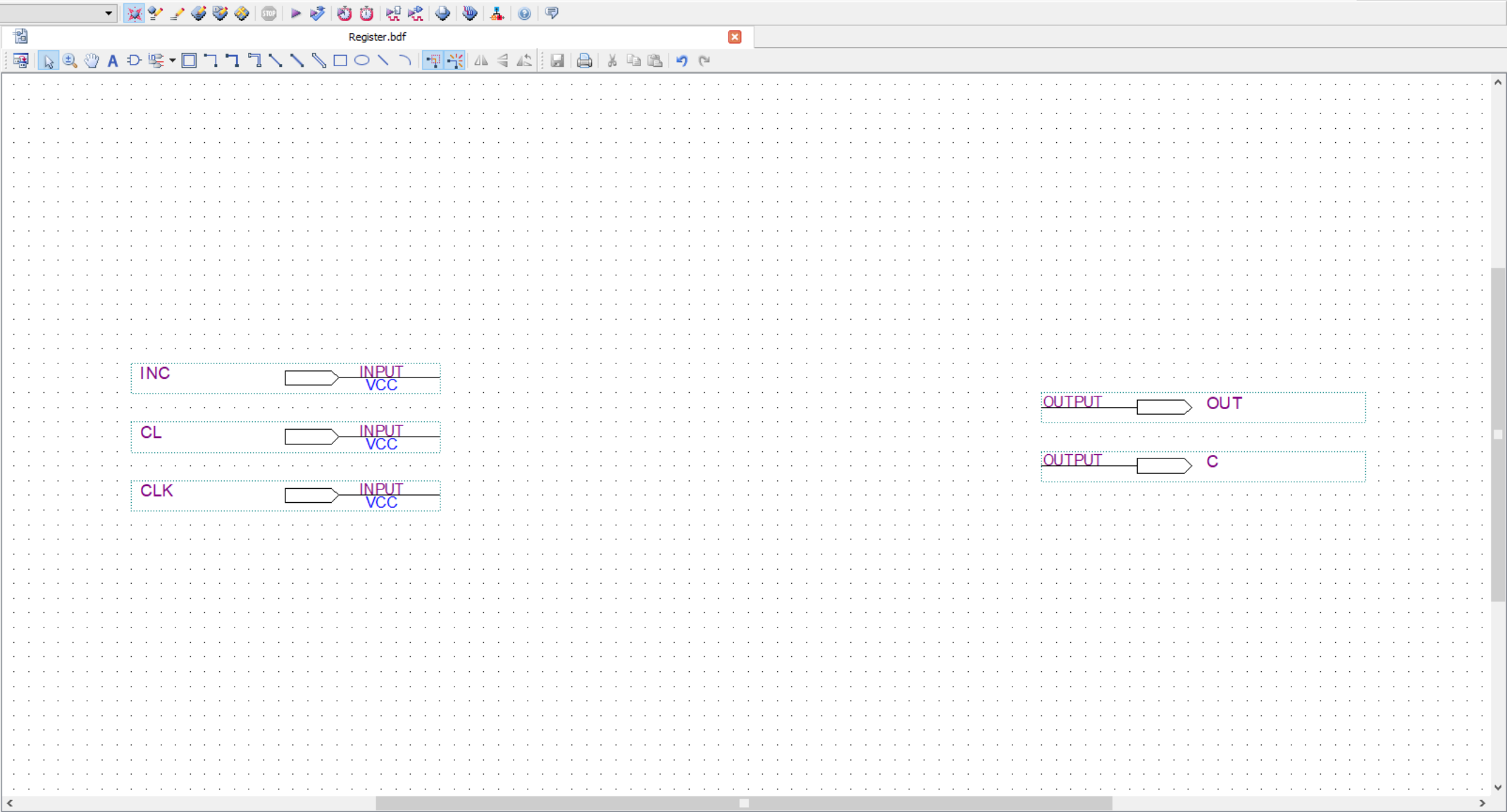

Messages

Type	ID	Message
------	----	---------

System / Processing

Project Navigator

Entity

- Cyclone III: EP3C16F484C6
  - Tastatura
    - UA:inst
      - RisingEdgeDetector:inst38
        - Debouncer:inst39
          - Register:inst2
          - Register:inst3
          - Register:inst4
        - P:inst1
        - UB:inst2

Tasks

Flow: Compilation

Task
Compile Design
Analysis & Synthesis
Fitter (Place & Route)
Assembler (Generate programming files)
TimeQuest Timing Analysis
EDA Netlist Writer
Program Device (Open Programmer)

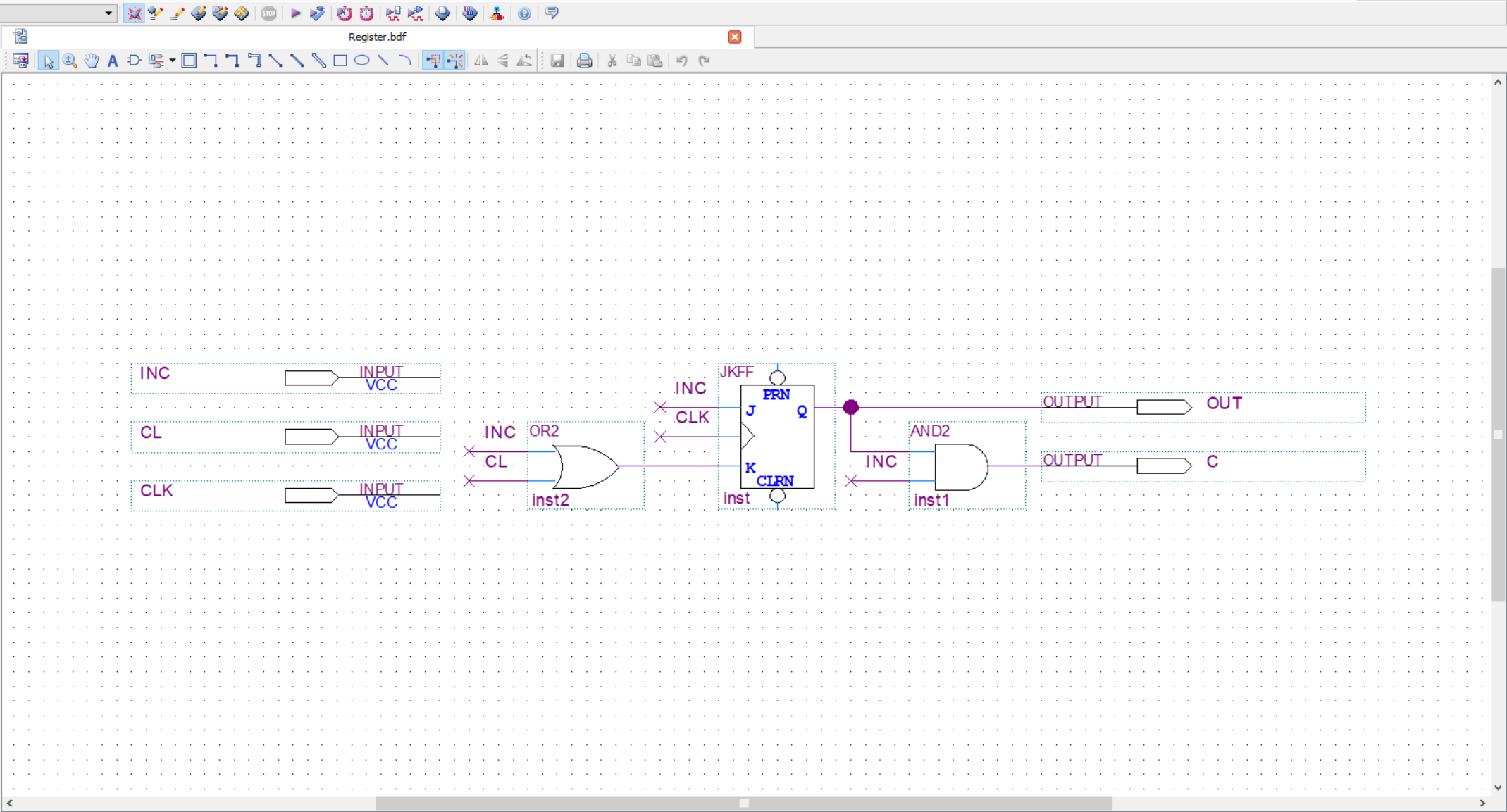

Messages

Type	ID	Message
------	----	---------

System Processing